

Owner's Manual

Parts Manual

READ THIS MANUAL CAREFULLY,
IT CONTAINS IMPORTANT SAFETY INFORMATION.

JUNOIR SPORT

JS80IIR

MINIMUM
RECOMMENDED
OPERATOR AGE: **10**

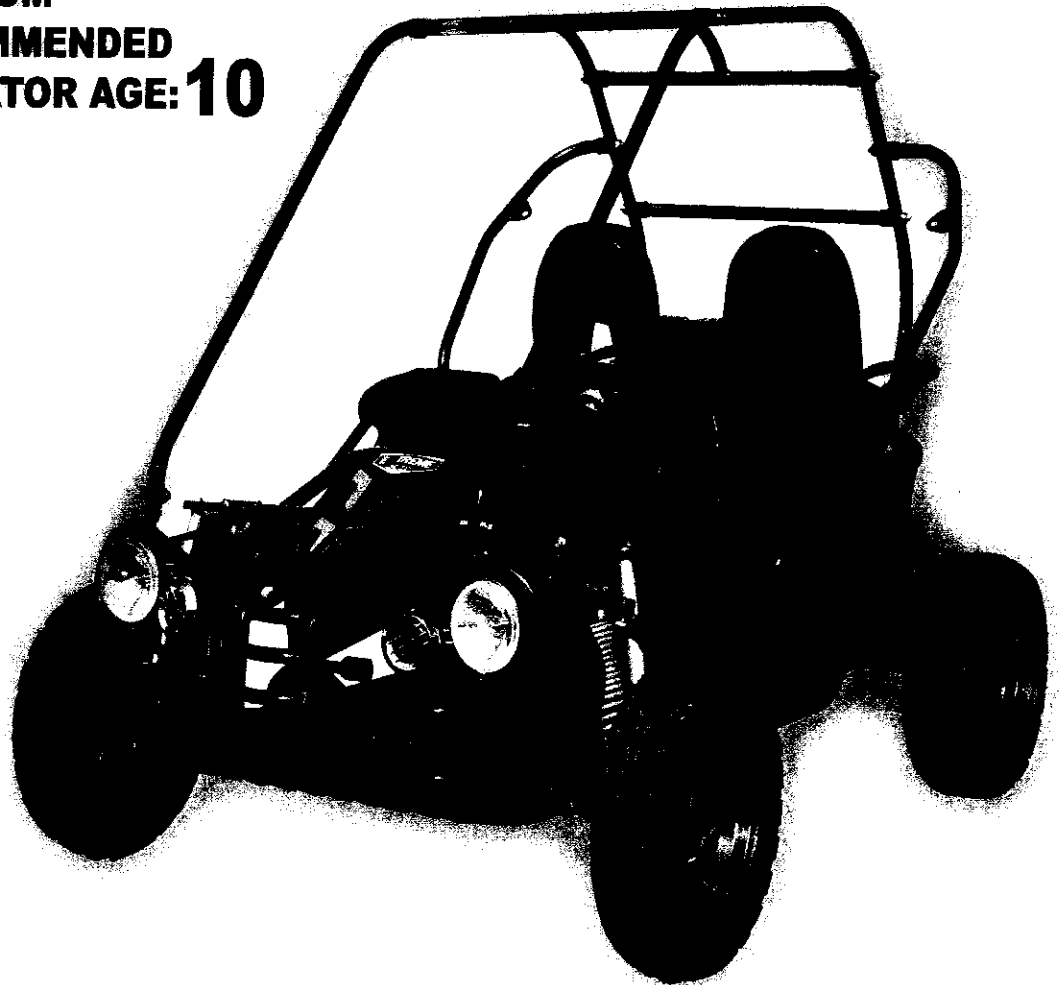

FOR OFF-ROAD USE ONLY

This vehicle is designed and manufactured for off-road use only.

USA only:

It does not conform to Federal Motor Vehicle Safety Standards, and in regards to operation on public streets, roads, or highways is illegal.

JS80IIR Limited Warranty

This warranty policy only applies vehicles unloaded from their shipping containers, set up and delivered by an authorized dealer, and that under normal use and service is found to have defects in parts or workmanship under the following terms and conditions. This warranty covers the kart and engine related components for a period of 90 days.

This warranty does not apply to any part, which in opinion of seller was defective because of improper maintenance, improper assembly, alterations, abuse, negligence or accident.

Should warranty service be required on your JS80IIR during the 90 days warranty period, please contact your nearest authorized dealer for repairs.

What is not covered under this warranty

Damage or faults caused by misuse, negligence, alterations, accidents or any abnormal use including the use of non genuine parts, renting or leasing, competition or racing. This warranty does not cover loss of use of the unit or loss of time, or inconvenience or normal wear and deterioration of consumable items such as spark plugs, chain, brake shoes, fuses, clutch plates, sprockets, light bulbs, battery and tires.

OWNER' S MANUAL

	Page
1. FOREWORD	1
2. A FEW WORDS ABOUT SAFETY	2
3. IMPORTANT SAFETY INFORMATION	3
4. SAFETY LABELS	5
5. ARE YOU READY TO DRIVE ?	6
6. IS YOUR VEHICLE READY TO DRIVE?	7
7. SAFE DRIVING PRECAUTIONS	8
8. P.D.I.	10
9. SPECIFICATIONS	11
10. OPERATION	13
11. SERVICE INSTRUCTIONS	18
12. REPAIR	19
13. PERIODICAL CHECK AND SERVICES	23

PARTS MANUAL

	Fig
1. CYLINDER HEAD ASSY.	Fig. 1
2. CYLINDER ASSY.	Fig. 2
3. CRANKCASE ASSY.(1).....	Fig. 3
4. CRANKCASE ASSY.(2)	Fig. 4
5. CRANKSHAFT CON'ROD &PISTON ASSY.	Fig. 5
6. CAMSHAFT ASSY.	Fig. 6
7. LEFT COVER ASSY.	Fig. 7
8. FAN COVER AND SHROUD ASSY.	Fig. 8
9. ELECTRIC SYSTEM.....	Fig. 9
10. ELECTRIC STARTER ASSY.	Fig.10
11. CARBURETOR	Fig.11
12. FRAME GROUP	Fig.12
13. STEERING SHAFT ASSY.	Fig.13
14. SUSPENSION ARM ASSY.	Fig.14
15. REAR SWING ARM	Fig.15
16. REAR HOUSING	Fig.16
17. TANK AND REVERSE LEVER	Fig.17
18. WIRE HARNESS/ELECTRICAL/SEATS/ENGINE	Fig.18
19. WARNING STICKERS	Fig.19

FOREWORD

Thank you for purchasing our kart. We hope you will enjoy it. Before you start to operate the kart, please read through this Owner's Manual carefully as it contains important safety and maintenance information. Failure to follow the warnings contained in this manual can result in serious injuries or death.

Be sure to follow the recommended maintenance schedule and service your kart accordingly. Preventive maintenance is extremely important to the longevity of your kart.

Beginners should seek instruction from your dealer or qualified instructors before and during initial use of the kart. It is also recommended to practice in a large flat open area to familiarise yourself with operations of this kart.

We hope you will have a pleasant experience with our products and thank you again for choosing our kart.

A FEW WORDS ABOUT SAFETY

In order to keep everyone safe, you must take responsibility for the safe operation of your kart.

To help you make informed decisions about safety, we have provided operating procedures and other information on labels and in this manual. This information alerts you to potential hazards that could hurt you or others.

It is not practical or possible to warn you about all hazards associated with operating or maintaining a kart. You must use your own good judgment.

You will find important safety information in a variety of forms, including:

Safety Labels – On the kart.

Safety Messages – Preceded by a safety alert symbol  and one of two signal words: **WARNING**, or **CAUTION**.

These signal words mean:



Physical harm may result from failure to adhere to the instructions that are described within the **WARNING** labels.

Safety Headings — such as Important Safety Reminders or Important Safety Precautions.

Safety Section — such as Kart Safety.

Instructions — how to use this kart correctly and safely.

This entire manual is filled with important safety information—please read it all carefully.

IMPORTANT SAFETY INFORMATION

Your kart will provide you with many years of use and pleasure. Providing you take responsibility for your own safety and that of any one else using your kart or near to the kart when it is being used and understand the challenges you can meet while driving.

There is much that you can do to protect yourself while operating your kart. You will find many helpful recommendations throughout this manual. The following are a few that we consider to be the most important.

Follow the Age Recommendation

The kart should not be driven by anyone under the age of 16.

Always Wear a Helmet

It's a proven fact: helmets significantly reduce the number and severity of head injuries. Always wear an approved motorcycle helmet. We also recommend that you wear eye protection, sturdy boots, gloves, and other protective gear.

Drive Off-Road Only

Your kart is designed and manufactured for off-road use only. The tires are not made for use on pavements, and the kart does not have turn signals and other features required for use on public roads. If you need to cross a paved or public road, get off and walk your kart across.

Take Time to Learn & Practice

Even if you have driven other karts, take time to become familiar with how this kart works and handles. Practice in a safe area until you build your skills and get accustomed to this kart's size and weight.

Because many accidents involve inexperienced or untrained drivers, we urge all drivers to take a training course. Check with your dealer for more information on training courses.

Be Alert for Off-Road Hazards

The terrain can present a variety of challenges when you drive off-road. Continually "read" the terrain for unexpected turns, drop-offs, rocks, ruts, and other hazards. Always keep your speed low enough to allow time to see and react to hazards.

IMPORTANT SAFETY INFORMATION

Drive within Your Limits

Pushing limits is another major cause of kart accidents. Never drive beyond your personal abilities or faster than conditions warrant. Remember that alcohol, drugs, fatigue, and inattention can significantly reduce your ability to make good judgments and drive safely.

Don't Drink and drive

Alcohol and driving don't mix. Even one drink can reduce your ability to respond to changing conditions, and your reaction time gets worse with every additional drink. So don't drink and drive, and don't let your friends drink and drive either.

Do not operate this kart at night.

Dark vision can greatly reduce a driver's visibility and judgment. So driving at night is dangerous and can increase the possibility for an accident.

Never run your kart indoors.

The exhaust from the engine contains a tasteless, odorless and poisonous gas called carbon monoxide.

Keep away from moving parts of the kart

The operator of the kart should never place their hands or other parts of their body near any moving part of the kart. Failure to adhere to this warning will cause physical harm to your body.

Skidding or Sliding

The terrain surface can be a major factor affecting turns. Skidding in a turn is more likely to occur on slippery surfaces such as snow, ice, mud and loose gravel. If you skid on ice, you may lose all directional control. To avoid skidding on slippery terrain, keep your speed low and drive carefully.

SAFETY LABELS

This section presents some of the most important information and recommendations to help you drive your kart safely. Please take a few moments to read these pages.

The labels should be considered permanent parts of the kart. If a label comes off or becomes hard to read, contact your dealer for warning label replacements.

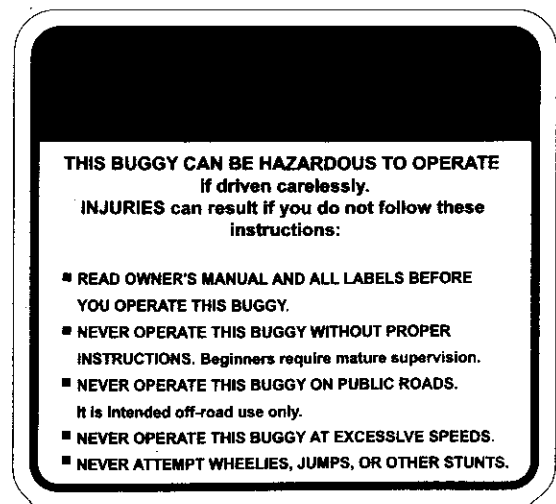
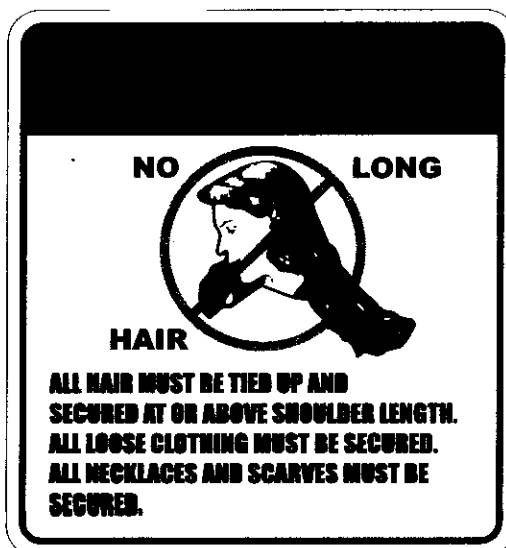
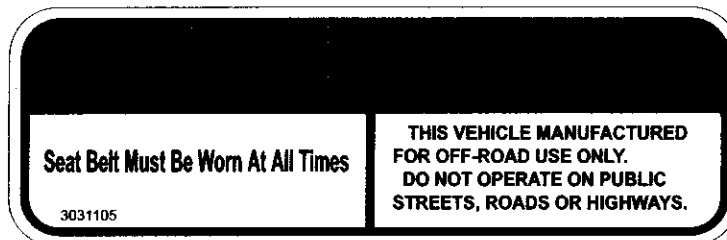
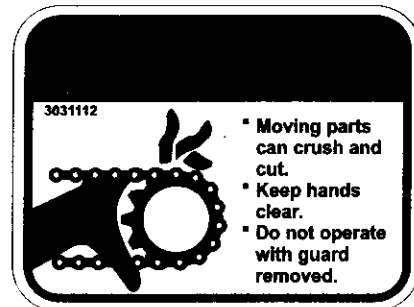

ARE YOU READY TO DRIVE ?

Before each drive, you need to make sure that you and your kart are both ready to drive. To help get you prepared, this section discusses how to evaluate your driving readiness, what items you should check on your kart, and adjustments to make for your comfort, convenience, or safety.

Before you drive your kart for the first time, we urge you to:

- Read this owner's manual and the labels on your kart carefully.
- Make sure you understand all the safety messages.
- Know how to operate all the controls.

Before each drive, be sure:

- You wear your seat belt at all times while driving your kart.
- You feel well and are in good physical and mental condition.
- You are wearing an approved motorcycle helmet (with chin strap tightened securely), eye protection, and other protective clothing.
- You don't have any alcohol or drugs in your system.

Protective Apparel

For your safety, we strongly recommend that you always wear an D.O.T. approved motorcycle helmet, eye protection, boots, gloves, long pants, and long-sleeved shirt or jacket whenever you drive.

Although complete protection is not possible, wearing proper gear can reduce the chance of injury should you have an accident.

The following suggestions will help you choose the proper protective gear.

Helmets and Eyes Protection

Your helmet is your most important piece of protective gear because it offers the best protection against head injuries. A helmet should fit your head comfortably and securely.

An open-face helmet offers some protection, but a full-face helmet offers more. Regardless of the style, look for a D.O.T. (Department of Transportation) sticker on any helmet you buy. Always wear a face shield or goggles to protect your eyes and help your vision.

WARNING

Operating this kart without wearing an approved motorcycle helmet, eye protection, and protective clothing could increase your chances of head and/or eye injury, and the possibility of death in the event of a severe accident.

Always wear an approved motorcycle helmet that fits properly and wear eye protection (goggles or face shield), gloves, boots, long-sleeved shirt or jacket and long pants.

ARE YOU READY TO DRIVE ?

Additional Driving Gear

In addition to a helmet and eye protection, we also recommend:

- Sturdy off-road motorcycle boots to help protect your feet, ankles, and lower legs.
- Off-road motorcycle gloves to help protect your hands.
- Driving pants with knee and hip pads, a driving jersey with padded elbows, and a rider protector.

Driver Training

Developing your driving skills is an on-going process. Even if you have driven other karts, before take time to become familiar with how this kart works and handles. Practice driving the kart in a safe area to develop your skills. Do not drive on rough terrain until you get accustomed to the kart's controls, and feel comfortable with its size and weight.

WARNING

Operating this kart without your seat belt could cause you to be thrown from the kart, causing serious injury or death.

No Alcohol or Drugs

Alcohol, drugs and karts don't mix. Even a small amount of alcohol can impair your ability to operate a kart safely. Likewise, drugs—even if prescribed by a physician—can be dangerous while operating a kart. Consult your doctor to be sure it is safe to operate a vehicle after taking medication.

WARNING

Operating this kart after consuming alcohol or drugs can seriously affect your judgment, cause you to react more slowly, affect your balance and perception, and could result in serious injury or death.

Never consume alcohol or drugs before or while operating this kart.

IS YOUR VEHICLE READY TO DRIVE?

Before each drive, it is important to inspect your kart and make sure any problems you find are corrected. A pre-drive inspection is a must, not only for safety, but because having a breakdown, or even a flat tire, can be a major inconvenience.

If your kart has overturned or has been involved in a collision, do not drive it until your kart has been inspected by your dealer. There may be damage or other problems that you can not see.

WARNING

Improperly maintaining this kart or failing to correct a problem before driving can cause a crash in which you can be seriously hurt or killed.

Always perform a pre-drive inspection before every drive and correct any problems.

SAFE DRIVING PRECAUTIONS

Off-Road Use Only

Your kart and its tires are designed and manufactured for off-road use only, not for use on paved surfaces. Driving on paved surfaces can affect the kart handling and control.

WARNING

Operating this kart on paved surfaces may seriously affect handling and control of the kart, and may cause the vehicle to go out of control.

Never operate the kart on any paved surfaces, including sidewalks, driveways, parks lots and streets.

When driving off-road, also remember to always obey local off-road driving laws and regulations. Obtain permission to drive on private property. Avoid posted areas and obey "no trespassing" signs.

You should never drive your kart on public streets, roads or highways, even if they are not paved. Drivers of street vehicles may have difficulty seeing and avoiding you, which could lead to a collision.

WARNING

Operating this kart on public streets, roads or highways could cause a collision with another vehicle.

Never operate this kart on any public streets, roads or highways, whether they are dirt, gravel or paved surfaces.

Keep Hands and Feet on Controls

When driving your kart, always keep both hands on the steering wheel and both feet on the foot controls. It is important to maintain your balance and to control the kart. Removing hands or feet away from the controls can reduce your ability to react and control the kart.

WARNING

Removing your hands from the steering wheel or feet from the foot controls during operation can reduce your ability to control the kart or could cause you to lose your balance and fall off the kart.

Always keep both hands on the steering wheel and both feet on the foot controls of your kart during operation.

SAFE DRIVING PRECAUTIONS

Control Speed

Driving at excessive speed increases the chances of an accident. In choosing an appropriate speed, you need to consider the capability of your kart, the terrain, visibility and other operating conditions, plus your own skill and experience.

WARNING

Operating this kart at excessive speeds increases your chances of losing control of the kart, which can result in an accident.

Always drive at a speed that is appropriate for your kart, the terrain, visibility and other operating conditions, and your experience.

Use Kart on Unfamiliar or Rough Terrain

Before driving in a new area, always check the terrain thoroughly. Don't drive fast on unfamiliar terrain or when visibility is limited (it's sometimes difficult to see obstructions like hidden rocks, bumps, or holes in time to react).

WARNING

Failure to use extra care when operating this kart on unfamiliar terrain could result in the kart overturning or going out of control.

Go slowly and be extra careful when operating on unfamiliar terrain. Always be alert to changing terrain conditions when operating the kart.

Never drive past the limit of visibility. Maintain a safe distance between your kart and other off-road vehicles. Always exercise caution and use extra care on rough, slippery and loose terrain.

WARNING

Failure to use extra care when operating on excessively rough, slippery or loose terrain could cause loss of traction or vehicle control, which could result in an accident, including an overturn.

Do not operate on excessively rough, slippery or loose terrain until you have learned and practiced the skills necessary to control the kart on such terrain. Always be especially cautious on these kinds of terrain.

Do Not Perform Stunts

You should always operate your kart in a safe and reasonable manner. When driving, always keep all four wheels on the ground.

WARNING

Attempting wheelies, jumps, and other stunts increases the chance of an accident, including an overturn.

Never attempt stunts, such as wheelies or jumps. Don't try to show off.

P.D.I.

- a. Install RR. Shocks and tighten the nuts.
- b. Install Ball Head, Tie Rod, tighten the Castle Nut and insert the cotter Pin.
- c. Install Dust Seals, align the Ball Head Bolt, Knuckle Support to the square hole on the Lower A-Arm.
- d. Install Flange Nut and tighten it (> 88.9 foot lbs)
- e. Install Front Tires and tighten the nuts.
- f. Install Rear Tires, tighten the nuts, insert cotter Pin and put on the Rubber Cover.
- g. Raise the C.B.C custom bar cage as what picture shows
- h. Install C.B.C custom bar cage RR., put on R-Washer.
- i. Install Head-Rest.
- j. Check all nuts and bolts, wiring, cables, fuel line, switches and tire pressure.
- k. Fill battery with Acid and charge, check and fill the engine with the recommended oil.
- l. Fill fuel tank with Unleaded Gasoline, and turn on the ignition switch to start the engine.

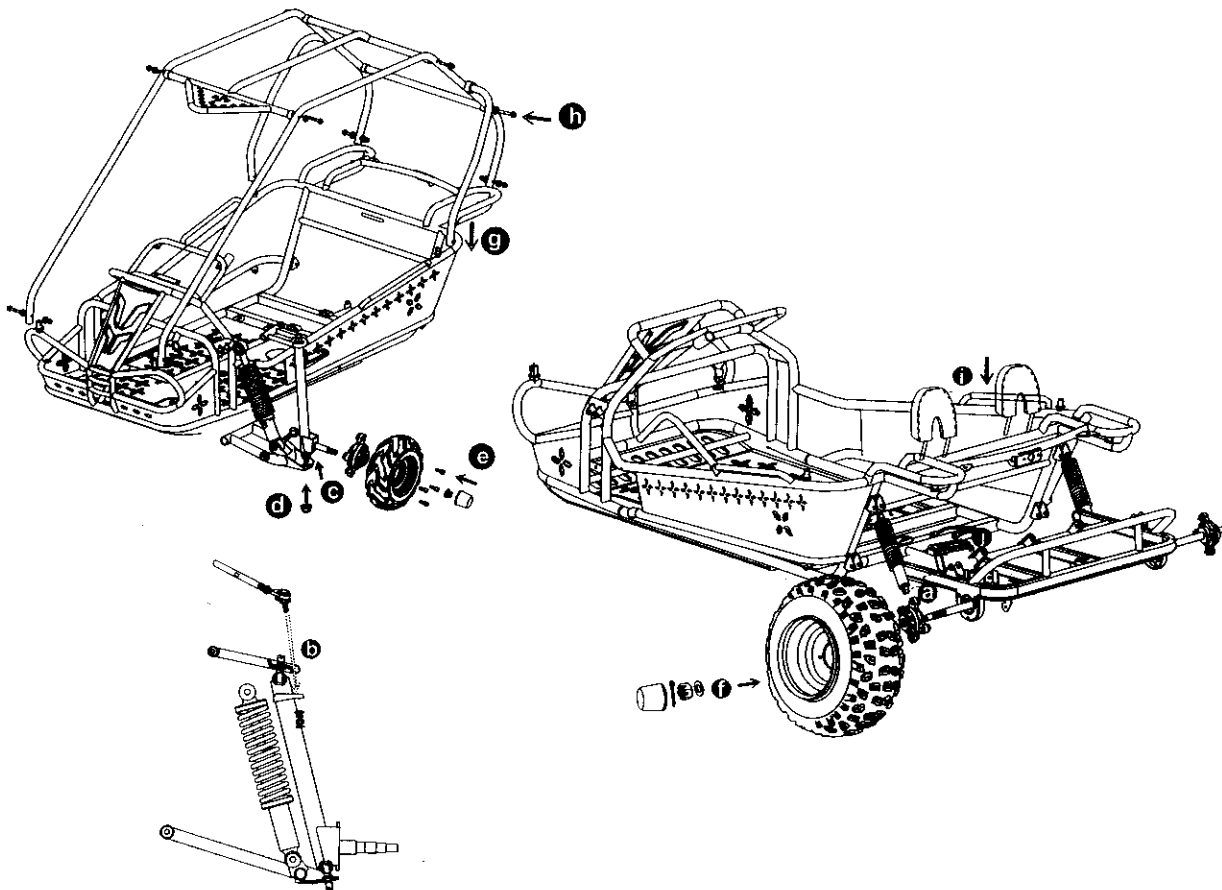

SPECIFICATIONS

DIMENSIONS

Overall Length	69 in. (1740mm)
Overall Width	45.6 in. (1160mm)
Overall Height	48.8 in. (1240mm)
Wheelbase	49.2 in. (1250mm)
Front Track	40.8 in. (1036mm)
Rear Track	34.8 in. (885 mm)
Ground Clearance	4.7 in. (120mm)

ENGINE

Type	Oil & Air cooled. 4-Stroke
Engine capacity	80cc
Bore / Stroke	47mm x 41.4mm
Corrected compression ratio	10.3:1
Carburator	PD20J
Output Power	2.8Kw/8000rpm
Maximum Torque	3.8/6500 foot lbs/r/min
Starting	Electric
Ignition	C.D.I.
Lubrication	Force & Splash
Transmission	CENTRIFUGAL
Spark plug	CRII7HSA
Plug gap	0.6-0.7mm
Fuel Type	RQ90 (unleaded)
Lubricate oil	SAE-10W/40

CAPACITIES

Maximum load	Double Seats/400lbs
Fuel tank	1.7 Gal
Engine oil	30 Oz
Starting	<5s
Climbing	20°-25°
Battery	12V 10Ah
Head Light	12V 20W/20W
Tail Light	12V 21W/5W
Fuse	10A

SPECIFICATIONS

Brake Track ----- < 7 m@20miles/h
Top speed ----- 25 miles/h(or limited as customers require)

CHASSIS

Front, Rear brake ----- Hydraulic disc, left foot control
Front tire ----- 16 x 3.5-8
Rear tire ----- 16 x 5.5 -8
Front Suspension ----- Independent Dual A-Arm
Rear Suspension ----- Swing Arm/Double Oil Damped Shock
Restraint System ----- Dual 4-point Harness
Final Drive Chain ----- (KMC) O-Ring Chain

TIRE PRESSURE

Front -----150kPa 1.5kg/cm² 21.3psi
Rear -----200kPa 2.0kg/cm² 28.4psi

WEIGHT

Net Weight ----- 321.8 lbs

A. Operation controls

WARNING - Do not attempt to start or operate the engine until completely familiar with the location and use of each control necessary to operate this vehicle. The operator must know how to stop this machine before starting and driving it.

a. Throttle

The right foot pedal is the throttle that controls the kart speed. As the engine speed increases above idle, the clutch automatically engages and moves the vehicle forward. To disengage the clutch at any time, allow the throttle to return to the idle position.

(See Fig. 1)

WARNING

Each time prior to starting the engine, check the throttle assembly to ensure that when the pedal is pushed all the way forward the assembly is working smoothly and returns to idle when released. Do not operate if pedal or engine throttle linkage fail to return to idle. If unable to correct the problem through lubrication, adjustment or replacement of worn parts, contact your dealer for assistance.

b. Brake

The brake is the left foot pedal (See Fig.1). Applying pressure to the pedal draws the brake caliper around the brake disc at the rear wheel and slows or stops the kart.

c. Start engine

Insert the key into key-switch, turn the key clockwise, release the key when the engine starts. The engine will warm up within 5 minutes and the engine choke will close automatically and operate at the normal RPM (Warning: Don't crank starter more than 5 seconds at one time).

d. Engine stop button

Important-stop button test.

Before driving this vehicle, test the Engine Stop Button to ensure that it is operating properly. With the engine running, push and hold the Engine Stop Button for two seconds for the engine to shut down.

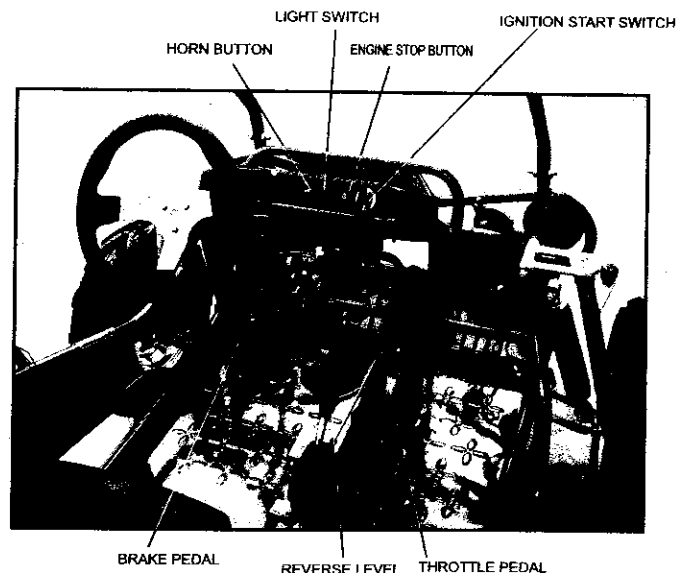

Figure 1

OPERATION

B. Pre-Drive Inspection



Perform this pre-drive inspection everyday before driving the vehicle. If not performed, serious damage to the vehicle or personal injury may result.

- a. Check the engine oil level is between the bottom of the dipstick and the "0" mark. Check for leaks. Add oil if required.
- b. Check the Fuel Level. Add fuel as necessary and do not overfill. Check for leaks. Ensure the fuel filler cap is securely fastened.
- c. Check the Brakes. Depress the left brake pedal several times, and check for adequate brake pedal freeplay. Make sure there is no brake fluid leakage.
- d. Check the tires. Check their condition for damage or excessive wear and pressure. The pressure on the front and rear tires is 15 and 20kPa respectively.
- e. Check the Drive Chain. Check its condition and tension. Lubricate if necessary.
- f. Check the Throttle Cable. Check for smooth operation. Ensure throttle "snaps" back to idle when released and moves smoothly without sticking.
- g. Check the Engine Stop Button. While the engine is running press and hold the engine stop button for 2 seconds. Make sure the engine stops.
- h. Check all Nuts, Bolts, and Fasteners. Check the wheels to see that all axle nuts and lug nuts are tightened properly. Check and tighten as necessary all other nuts, bolts and fasteners.
- i. Check the Brush Guard. Ensure all C.B.C. bars are in place before operating the kart.
- j. Check the Lights. Check the headlights, brake light and tail light are all working.
- k. Check the Steering. Check that the steering wheel moves freely in both directions but without any unusual looseness.
- l. Check all Cable Housings. Check these for wear and the fitting for any looseness.
- m. Check the underbody and exhaust system. Remove all dirt, vegetation and mud and check for any damage due to impact with rocks or uneven terrain.
- n. Check the Air Cleaner Housing Drain Tube. Check the deposits in the drain tube. If necessary, check the tube and air cleaner housing.
- o. Check Leaks and Loose Parts. Walk around your kart and look for anything that appears unusual, such as a leak or loose cable.
- p. Check the Parking Brake. Make sure the kart does not move forward or backward when the parking brake is applied.

Component locations

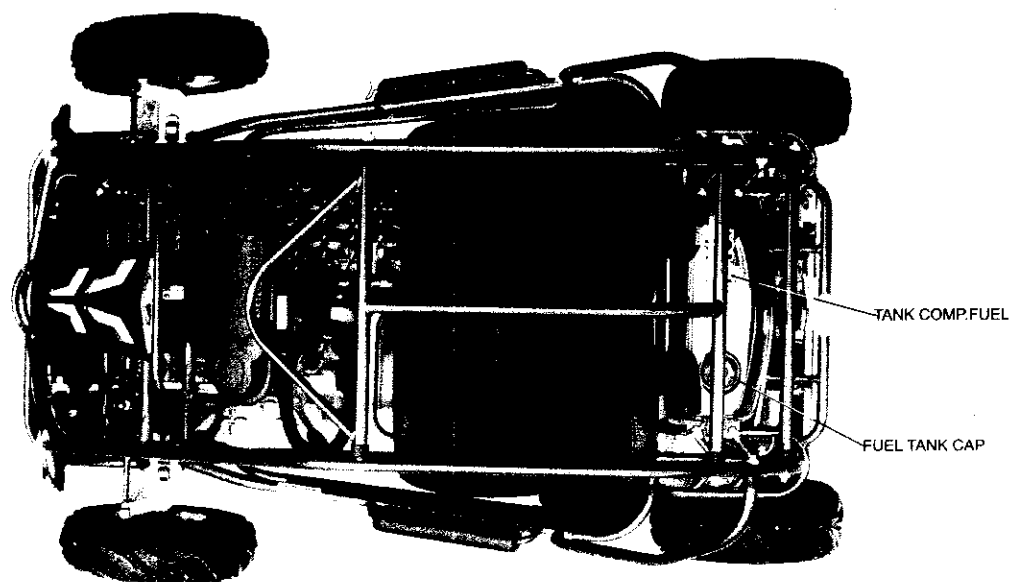
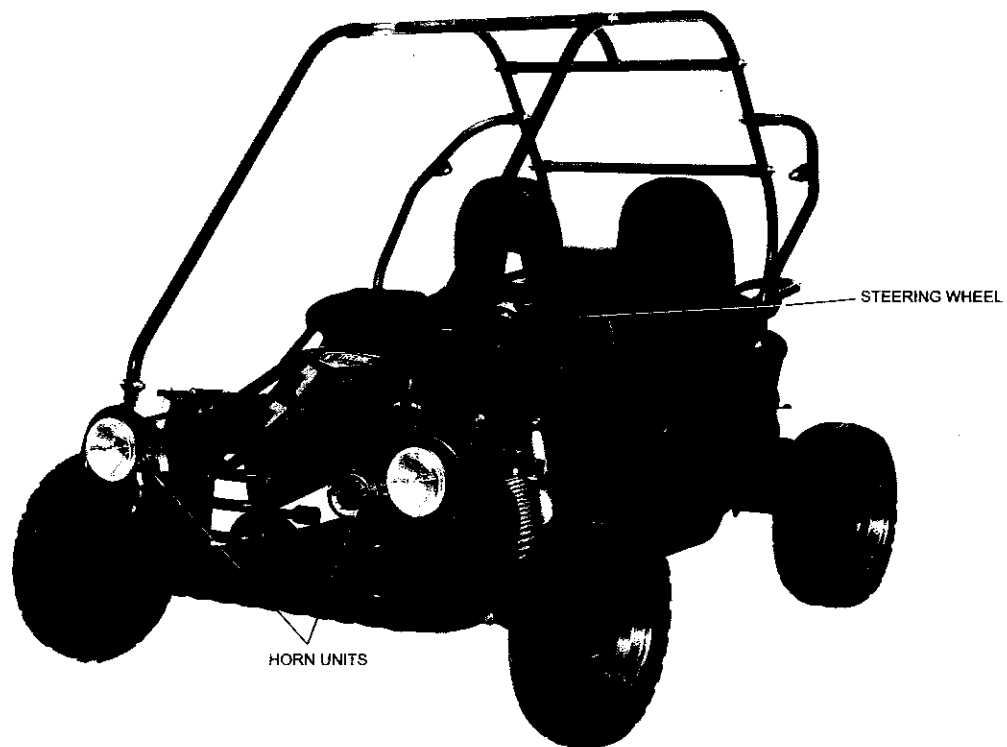

Figure 2

OPERATION

C. Passengers

The vehicle is designed for two people only. The combined maximum weight of the driver and the passenger should not exceed 180kg or 400lbs.

D. Seat Adjustment

The seat should be securely fastened in the position which gives the operator best control of the foot pedals, steering wheel, and the remote stop button.

- a. Pull the seat adjustment handle upward to disengage the seat slide.
- b. Move the seat to the desired position.
- c. Be sure that the seat adjustment handle snaps back into place and that seat is locked into position.

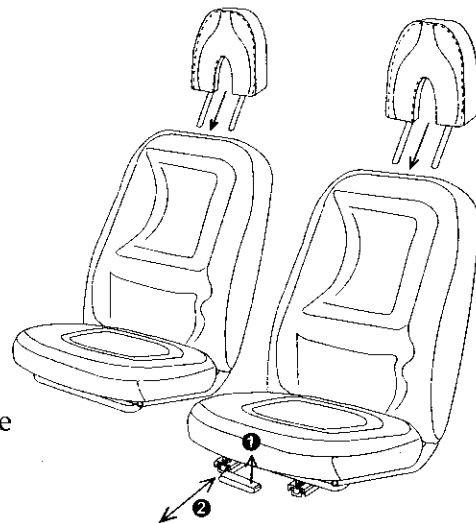

Figure 3

WARNING

Before attempting to adjust the seat, ensure that engine is stopped.

WARNING

Never operate this kart when the seat is not securely in place, to do so could result in personal injury or loss of life.

E. Forward and Reverse Gear

- a. Push the reverse lever forward to the "D" position for the kart to move forward, pull the lever back to "R" for the kart to move backward. (See Fig.4)
- b. When gear lever is in the drive position, there needs to be 1/2 inch of freeplay in the cable. If the adjustment is not correct, then loosen the lock nut #2, then adjust lock nut #1 to give the proper amount of freeplay.

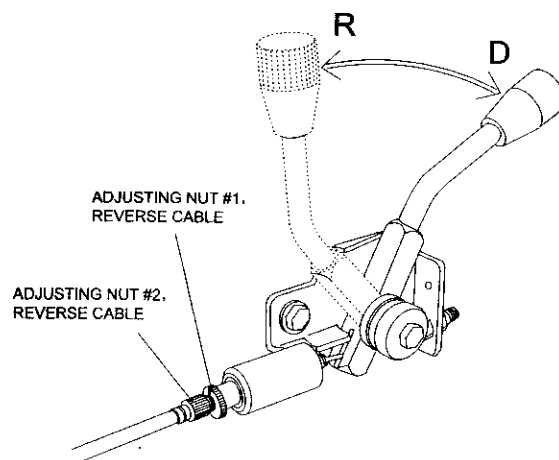

Figure 4

WARNING

Always stop the kart before changing gears.

F. Starting and Operating Instructions

- a. Before starting the engine, the driver must be seated properly in the kart with the seat belt on.
- b. Practice in the kart in an open space at the beginning to learn how to start, turn and stop the vehicle.
- c. Drive slowly until you are familiar with the operation of the kart.
- d. The turning radius of this kart is small and agile, so the centrifugal force is very high when turning at high speed. Slow down to a more controllable speed when turning to prevent the kart from rolling over. The driver should keep their heels on the ramp of the main board when turning. (See Fig.5) Keeping their leg on the foot pedal, the driver can feel that the kart is stable and won't roll over.

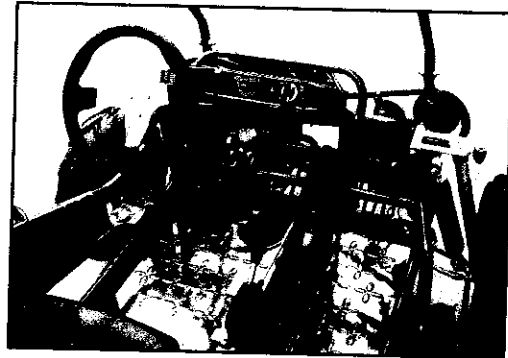
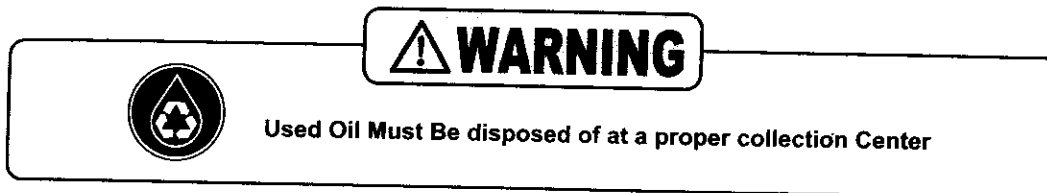

Figure 5

SERVICE INSTRUCTIONS

A. Engine Lubrication

You must change the oil in the crankcase after the first 5 hours of operating of your new engine (See Fig. 6) and after every 10 hours of use thereafter. This will insure proper lubrication of the internal parts and prevent costly repairs due to excessive wear.



- a. Remove the drain plug located on the right rear side of engine. Tip the kart backwards slightly by blocking up the front end and drain the oil into suitable container.
- b. Remove and clean the oil filter.
- c. Replace drain plug and tighten securely. Place the kart in a level position.
- d. Refill the crankcase (approximately 1 1/4 pint) to the top of the filler neck with SAE 10W40 oil.
- e. Check the oil level before each use of the kart or after each 10 hours of operation. Add oil when necessary to keep the level between the bottom of the dipstick and the "0" mark. Do not mix various grades of oil.

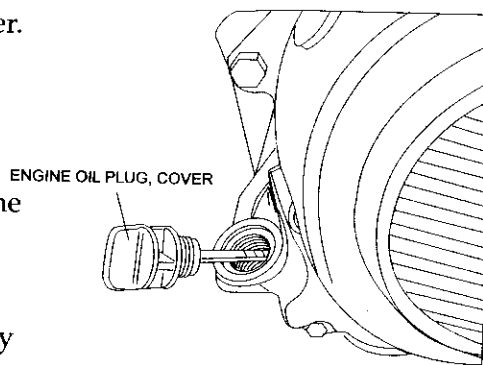

Figure 6

B. Spark Plug

- a. Remove the spark plug and inspect it each time you change the oil (Use a spark plug wrench). The electrodes should be kept clean and free of carbon. The presence of carbon or excess oil will greatly reduce engine performance. If possible, check the spark plug gap (area between electrodes) using a wire feeler gauge. This specification is 32-35 gap or 0.5-0.6mm.
- b. Before installing the spark plug coat the threads lightly with graphite grease if possible, to ensure easy removal next time the spark plug needs inspection.
- c. It is advisable to replace the spark plug at least once a year to ensure easy starting and good engine performance.

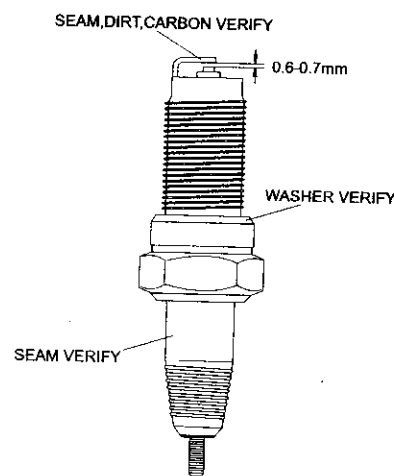

Figure 7

C. Cleaning Instructions

Keep your kart clean. With a clean rag, wipe off all dirt and oil from around the controls. Wipe off any spilled fuel and oil. Keep the engine clean of foreign objects, and be sure to check that the air intake fan is free of debris for proper cooling.

SERVICE INSTRUCTIONS

- a. Warm up the engine (5-10min)
- b. Tighten the air screw gently. Backout 2-3/8 turns counter clockwise.
- c. Connect the tachometer, adjust the throttle to limit the idle speed. The standard value is 1400RPM.
- d. Turn the air screw counter clockwise slowly and observe the RPM of the engine, stop adjusting as the RPM reaches the top speed.
- e. Adjust the screw and adjust the idle speed to an ideal value.
- f. Recheck and readjust the idle speed if necessary.

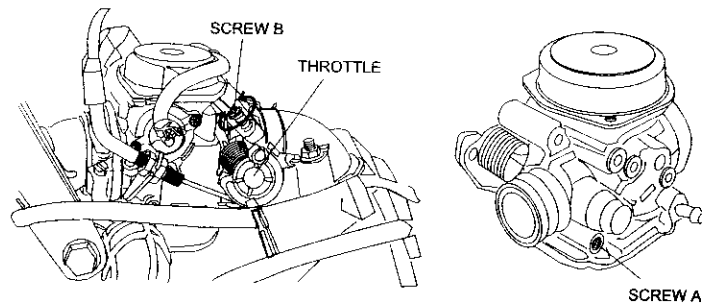

Figure 8

D. Cleaning Instructions

Keep your kart clean. With a clean rag, wipe off all dirt and oil from around the controls. Wipe off any spilled fuel and oil. Keep the engine clean of foreign objects, and be sure to check that the air intake fan is free of debris for proper cooling.

E. Buggy Lubrication

Lubricate the vehicle every 90 days of use. Lubrication should be done more often, if the kart is used everyday.

F. Chain Lubrication

To increase chain life, it should be lubricated with a spray on type chain lubricant. (See Fig. 9)

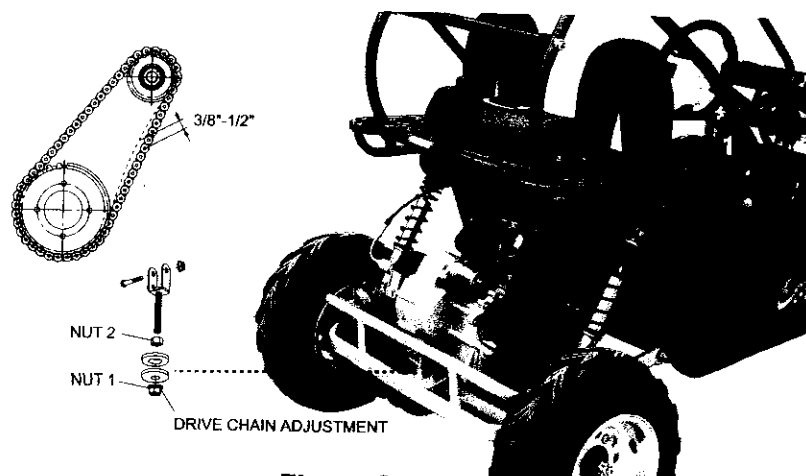

Figure 9

SERVICE INSTRUCTIONS

G. Buggy Lubrication

Lubricate the vehicle every 90 days of use. Lubrication should be done more often, if the kart is used everyday.

H. Adjustment of Front And Rear Shock

There are five adjustable positions on each shock. The default position is in the middle set by manufacturer (See Fig. 9)

Use a round nut wrench as you adjust the shock, the tension of shock spring will increase as you screw to left, decrease as you screw to right. Adjust according to the weight of the riders.

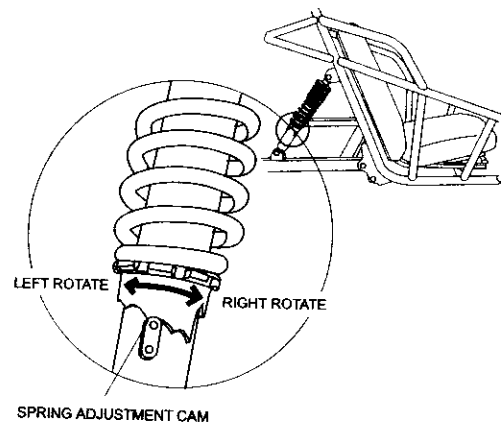

I. Storage Instruction

In the event your kart is not to be operated for a period in excess of 30 days or at the end of each driving season prepare for storage as follows:

- Drain fuel tank and carburetor by allowing engine to run out of fuel, and use a fuel stabilizer.
- Lubricate engine cylinder by removing the air cleaner, then spray engine fogging oil through the carburetor until the motor dies.
- Do not save or store gasoline over winter. Using old gasoline, which has deteriorated from storage, will make the engine difficult to start and affect engine performance.

Figure 9

WARNING

Do not drain fuel while engine is hot. Be sure to move the kart outside before draining fuel.

A Front Wheel Replacement

Do not disassemble the castle nuts when you replace the front wheels. It is only necessary to remove the 4 nuts to remove the wheel. (See Fig. 10) Tighten the nuts after replacing the wheels.

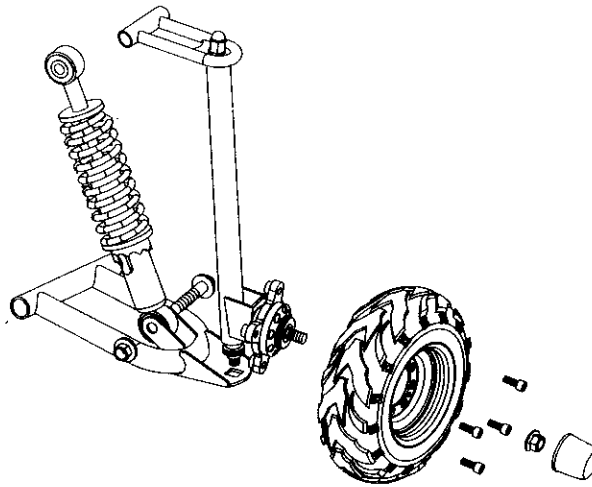

Figure 10

B. Rear Wheel Replacement

Do not disassemble the castle nuts when you replace the rear wheels and hub assembly. Remove the cotter pin and then 24mm nut. Then slide off the wheel and hub assembly. It is only necessary to remove the 4 nuts to remove the wheel.

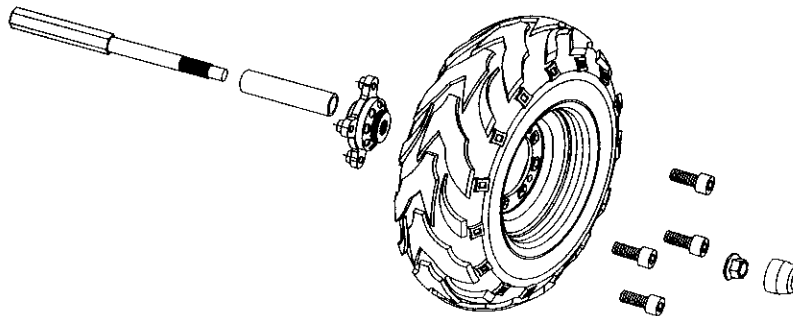

Figure 11

C. Front Wheel Alignment

a. The front wheels should be "toe-in" from 1/8" to 1/4". To check for alignment, measure distance A and B between the centerline (CL) of the wheels. The proper toe-in dimension A should be 1/8" - 1/4" greater than dimension B.

b. To adjust the alignments, loosen the lock nuts on both sides of Front Tie Rods. To make Dimension B smaller, turn the rod to left. Adjust the rod to right direction to make Dimension B larger. After adjusting to the desired length, tighten the lock nut against the rod end. Recheck the dimensions for proper alignment.

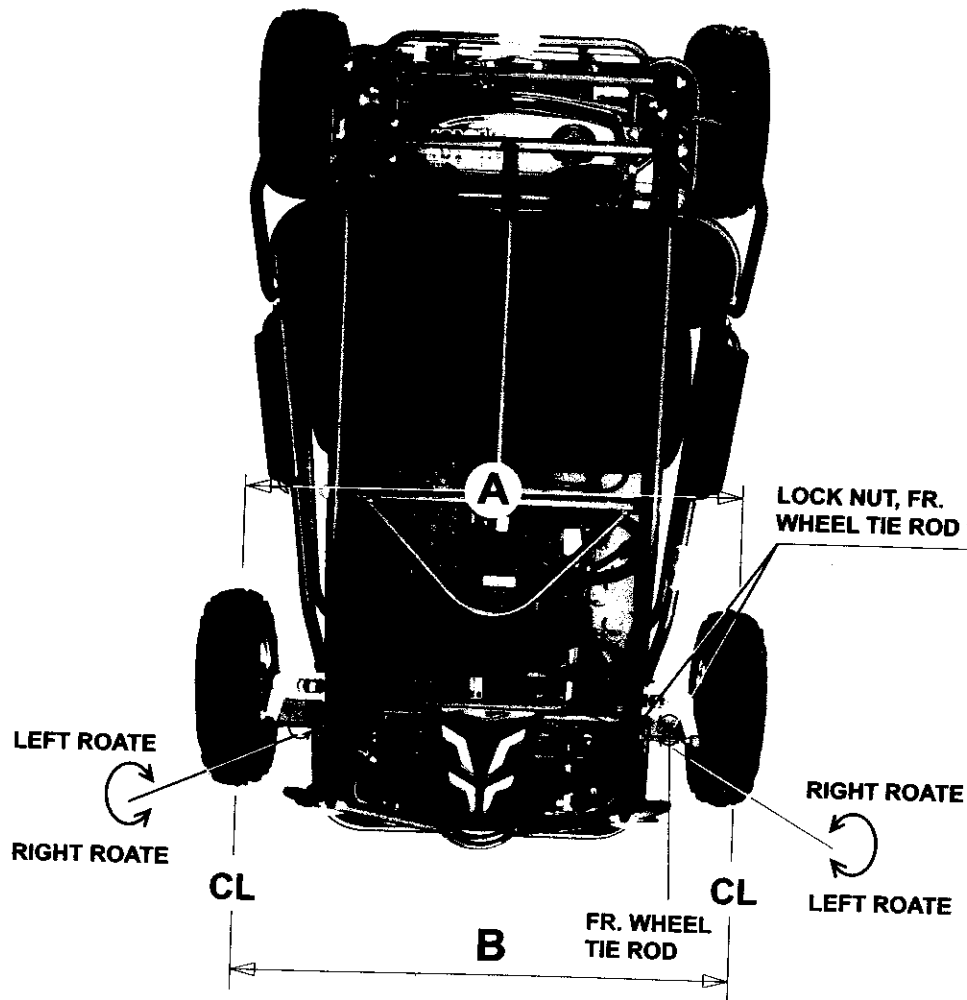
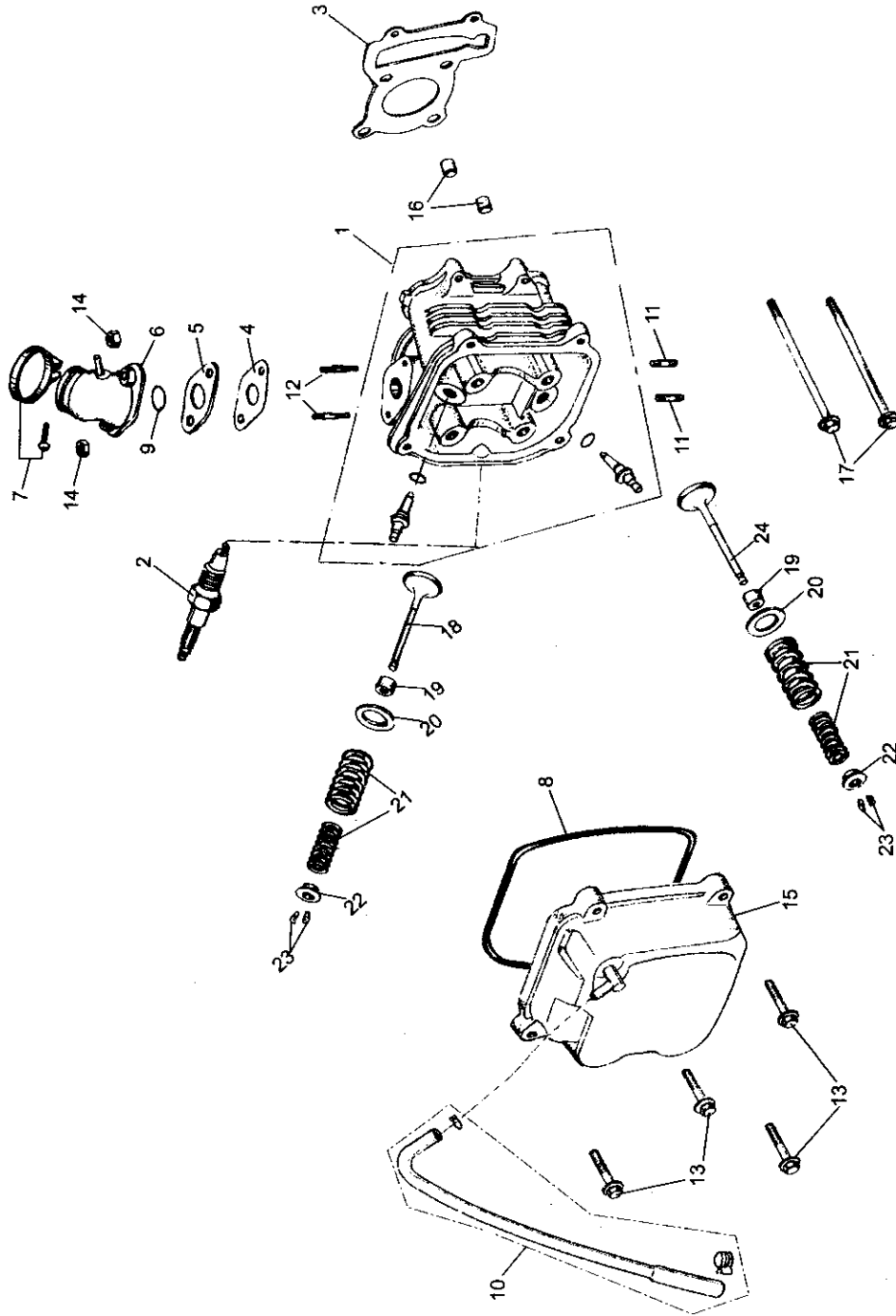

Figure 12

FIG. 1

CYLINDER HEAD ASSY.



CYLINDER ASSY.

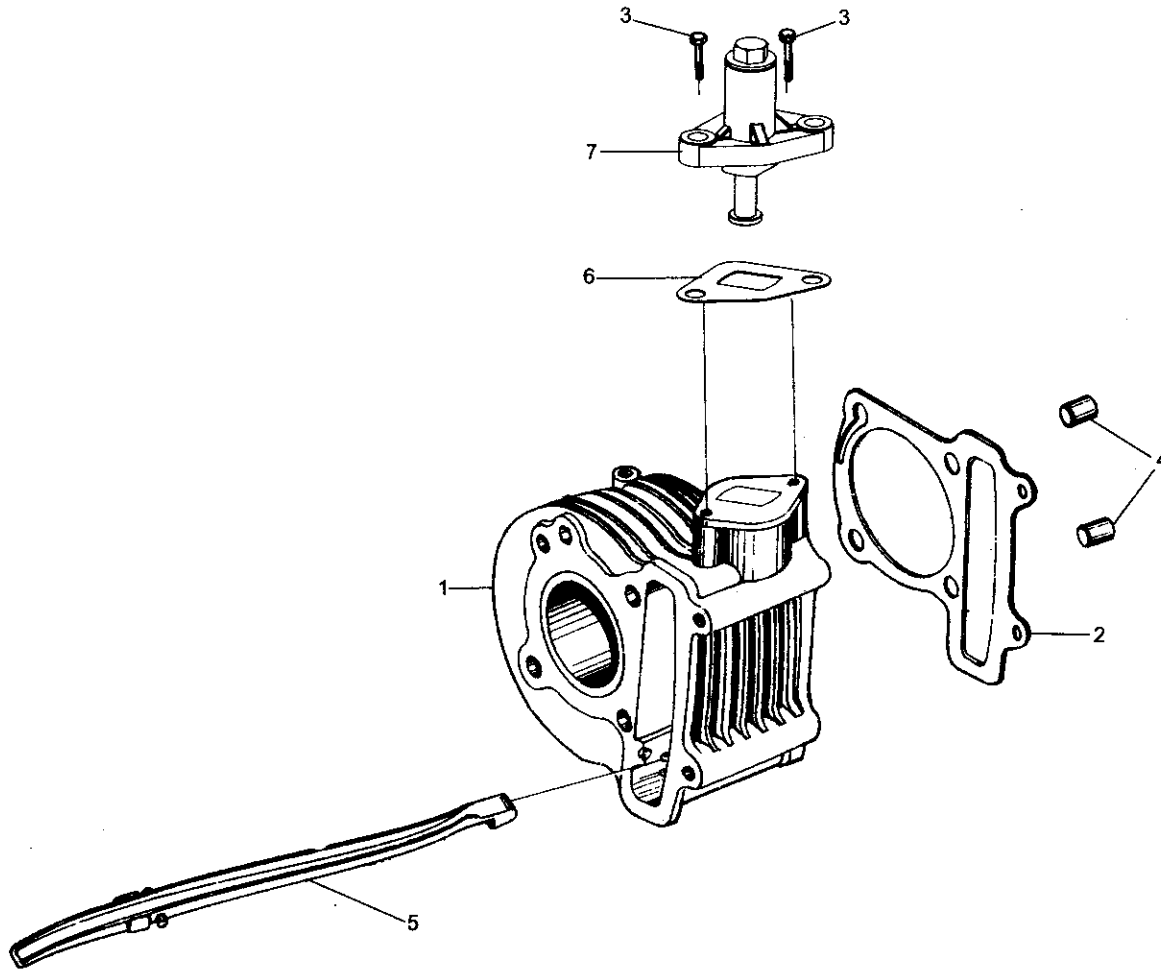

CYLINDER ASSY.				
REF NO.	PART NO.	DESCRIPTION	REGD NO.	
1	M80-102001	CYLINDER COMP.	1	
2	M80-102002	CYLINDER GASKET	1	
3	M80-102003	FLANGE BOLT 6X20	2	
4	M80-102004	DOWEL PIN 8X14	2	
5	M80-102005	CAM CHAIN GUIDE COMP.	1	
6	M80-102006	GASKET TENSIONER LIFTER	1	
7	M80-102007	TENSIONER LIFTER ASSY.	1	

CRANKCASE ASSY. (1)

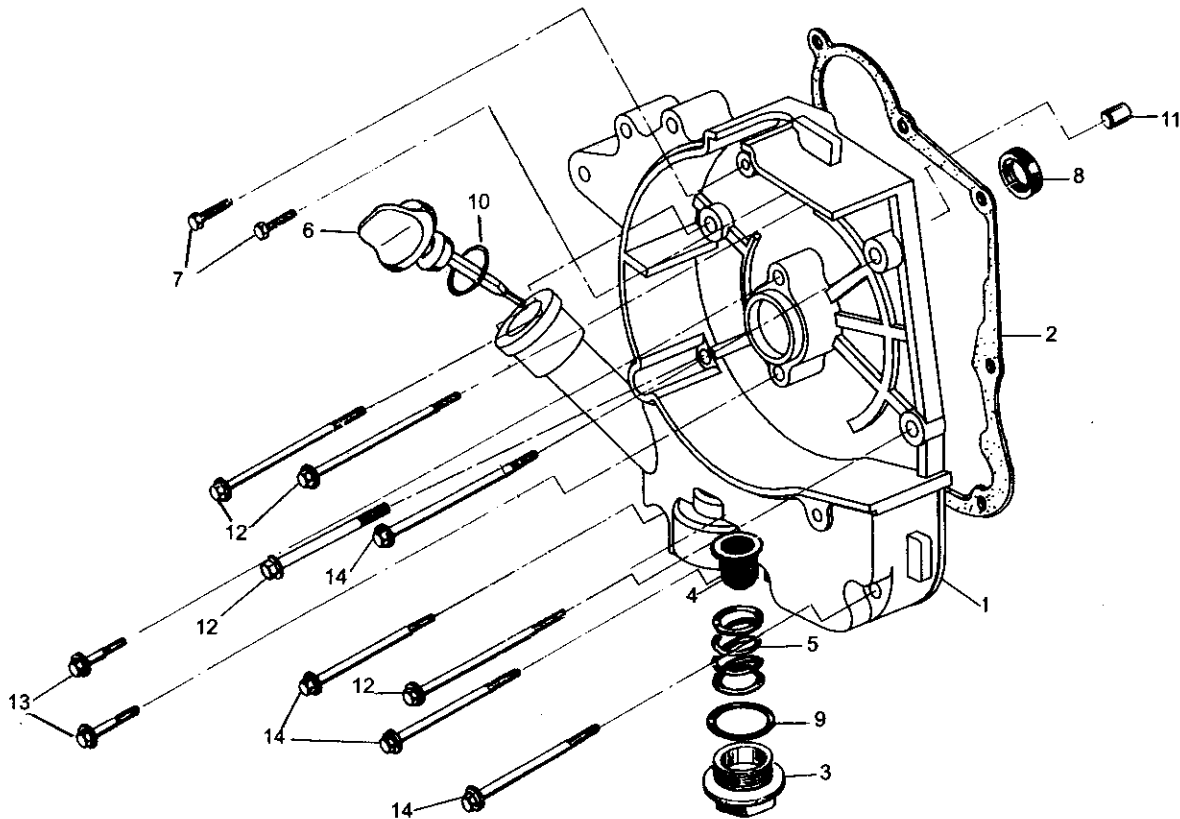

CRANKCASE ASSY.(1)

REF NO.	PART NO.	DESCRIPTION	REGD NO.
1	M80-103001	R CRANKCASE COVER COMP.	1
2	M80-103002	CRANKCASE COVER GASKET	1
3	M80-103003	CAP TAPPET ADJUSTING HOLE	1
4	M80-103004	OIL FILTING SCREEN	1
5	M80-103005	OIL FILTING SCREEN SPRING	1
6	M80-103006	OIL LEVEL GAUGE	1
7	M80-103007	HEX BOLT M5X12-ZN.D	2
8	M80-103008	OIL SEAL 16.4X30X5	1
9	M80-103009	O-RING 30.8X3	1
10	M80-103010	O-RING 18X3	1
11	M80-103011	DOWEL PIN 8X14	2
12	M80-103012	FLANGE BOLT M6X85	4
13	M80-103013	FLANGE BOLT M6X22	2
14	M80-103014	FLANGE BOLT M6X100	4

FIG.4

CRANKCASE ASSY. (2)

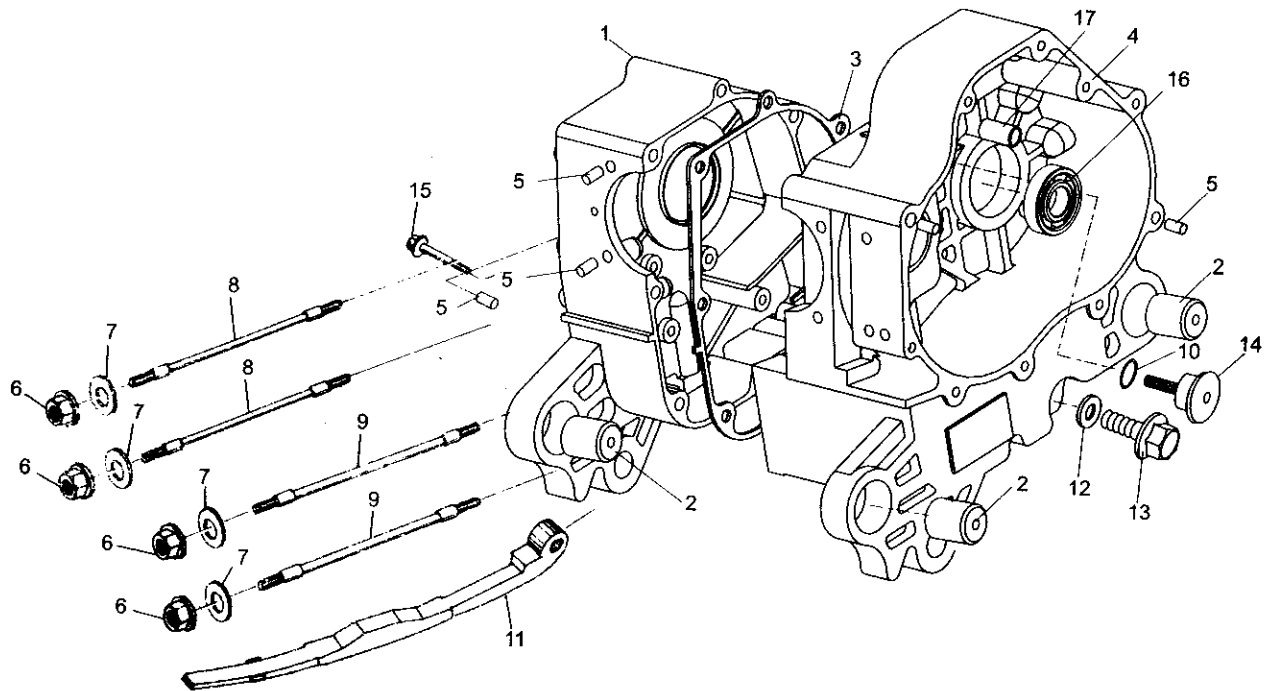

CRANKCASE ASSY.			
REF NO.	PART NO.	DESCRIPTION	REGD NO.
1	M80-104001	R. CRANKCASE ASSY.	1
2	M80-104002	ENGINE HANGER RUBBER BUSH	2
3	M80-104003	CRANKCASE GASKET	1
4	M80-104004	CRANKCASE ASSY. L	1
5	M80-104005	DOWEL PIN 8X14	6
6	M80-104006	FLANGE NUT M8	4
7	M80-104007	WASHER $\Phi 8$	4
8	M80-104008	STUD BOLT M8X167	2
9	M80-104009	STUD BOLT M8X175	2
10	M80-104010	OIL SEAL 15.2X12	1
11	M80-104011	CAM CHAIN TENSIONER	1
12	M80-104012	DRAIN PLUG WASHER $\Phi 12$	1
13	M80-104013	DRAIN PLUG BOLT M12	1
14	M80-104014	CAM CHAIN TENSIONER PIVOT	1
15	M80-104015	FLANGE BOLT M6X50	1
16	M80-104016	RADIAL BALL BEARING E6203	1
17	M80-104017		1

CRANKSHAFT CON'ROD & PISTON ASSY.

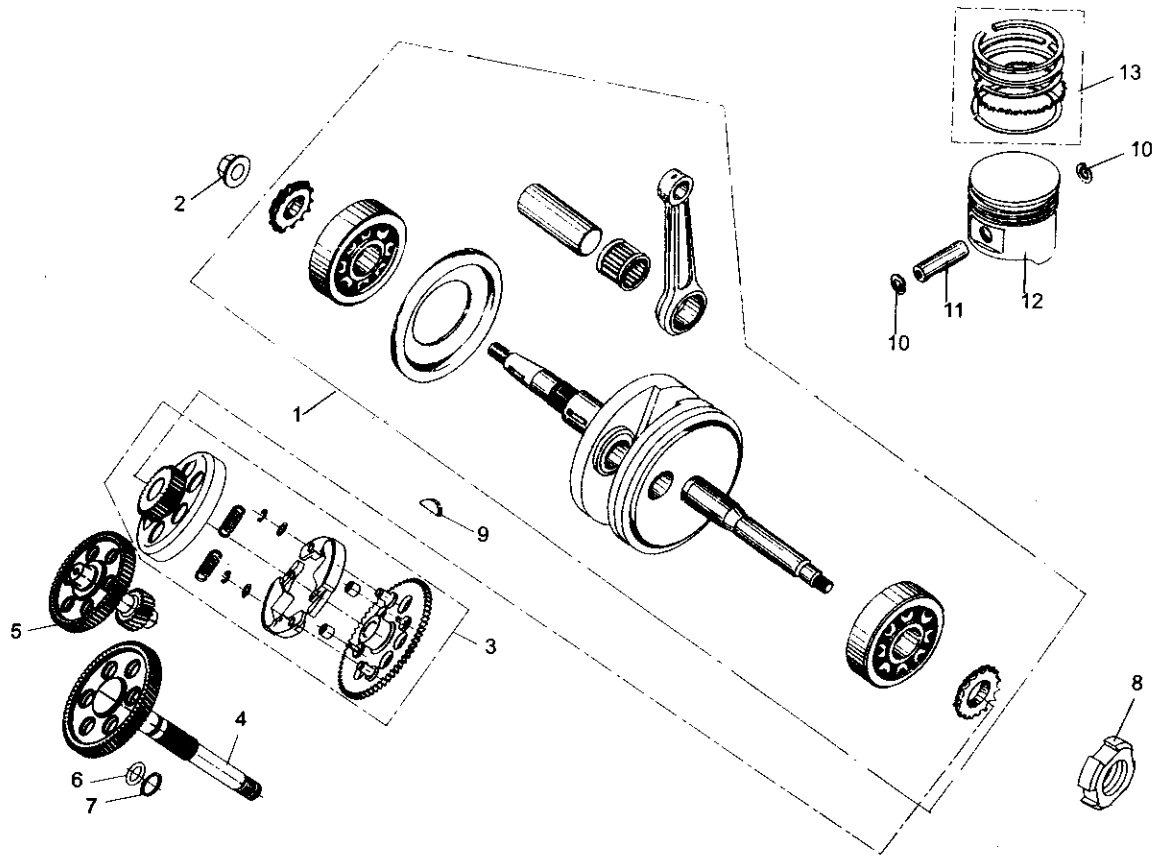

CRANKSHAFT CON'ROD & PISTON ASSY.

REF NO.	PART NO.	DESCRIPTION	REGD NO.
1	M80-105001	CRANKSHAFT & CONROD ASSY.	1
2	M80-105002	NUT M12X1.25	1
3	M80-105003	CLUTCH SUB ASSY.	1
4	M80-105004	OUTPUT SHAFT	1
5	M80-105005	MIDDLE SHAFT	1
6	M80-105006	O-RING	1
7	M80-105007	CIRCLIP	1
8	M80-105008	NUT M6	1
9	M80-105009	WOODRUFF KEY	2
10	M80-105010	PISTON PIN CLIP	2
11	M80-105011	PISTON PIN	1
12	M80-105012	PISTON	1
13	M80-105013	PISTON RING SET	1

CAMSHAFT ASSY.

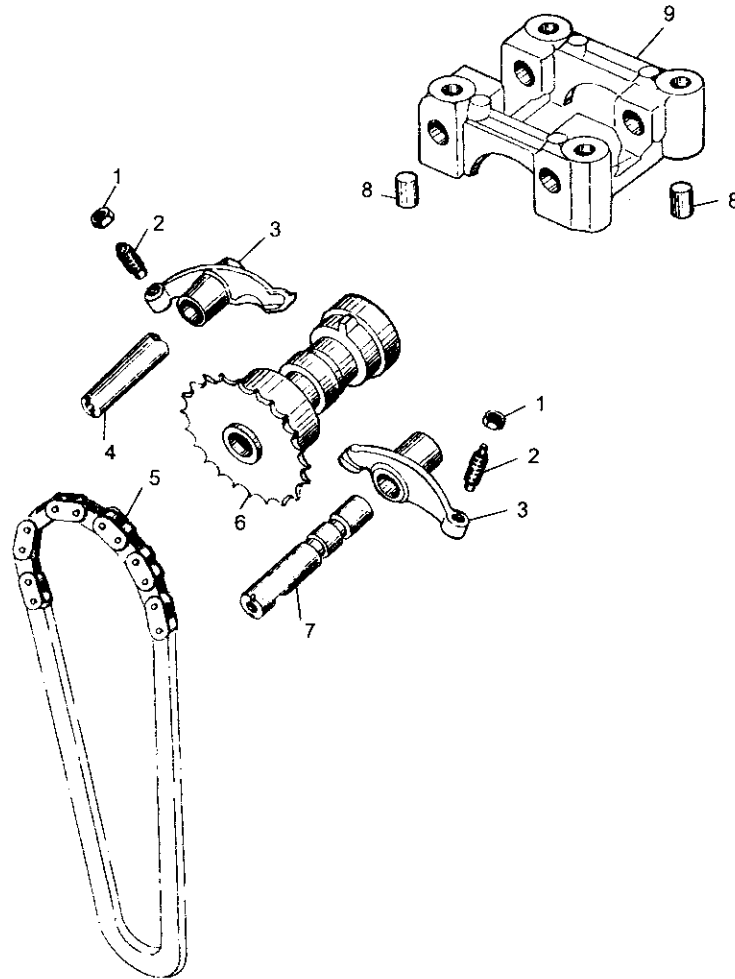

CAMSHAFT ASSY.				
REF NO.	PART NO.	DESCRIPTION	REGD NO.	
1	M80-106001	ADJUSTING TAPPET NUT	2	
2	M80-106002	ADJUSTING TAPPET SCREW	2	
3	M80-106003	ROCKER ARM VALVE	2	
4	M80-106004	EX. ROCKER ARM SHAFT	1	
5	M80-106005	CAMSHAFT CHAIN	1	
6	M80-106007	CAMSHAFT COMP. 16T	1	
7	M80-107007	IN ROCK ARM SHAFT COMP.	1	
8	M80-107008	DOWEL PIN 8X14	2	
9	M80-108009	CAMSHAFT HOLDER	1	

LEFT COVER ASSY.

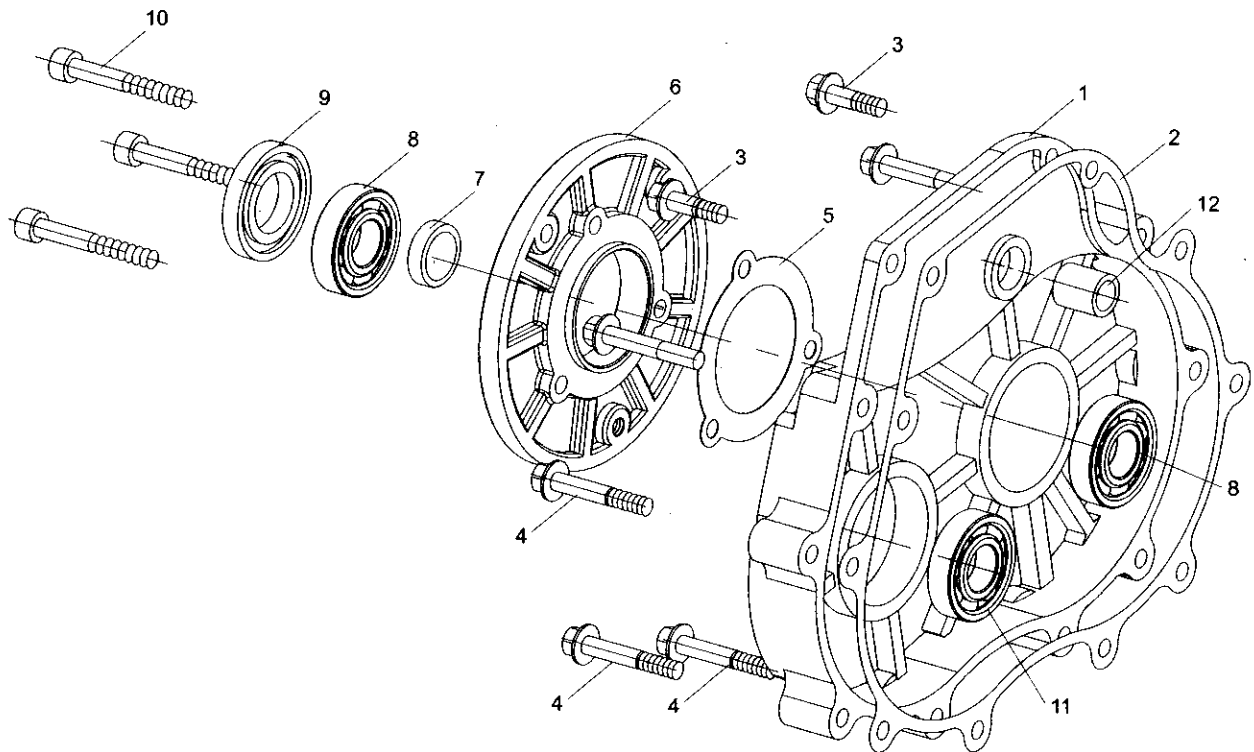

LEFT COVER ASSY.				
REF NO.	PART NO.	DESCRIPTION	REGD NO.	
1	M80-107001	L. COVER	1	
2	M80-107002	L COVER GASKET	1	
3	M80-107003	BOLT M6X20	2	
4	M80-107004	BOLT M6X35	8	
5	M80-107005	COVER L PLATE	1	
6	M80-107006	UNIDIRECTIONAL DISC.	1	
7	M80-107007	BUSHING	1	
8	M80-107008	BEARING 6004	2	
9	M80-107009	DUST SEAT	1	
10	M80-107010	ALLEN HEAD BOLT	3	
11	M80-107011	BEARING 6203	1	
12	M80-107012	BUSHING	1	

FAN COVER AND SHROUD ASSY.

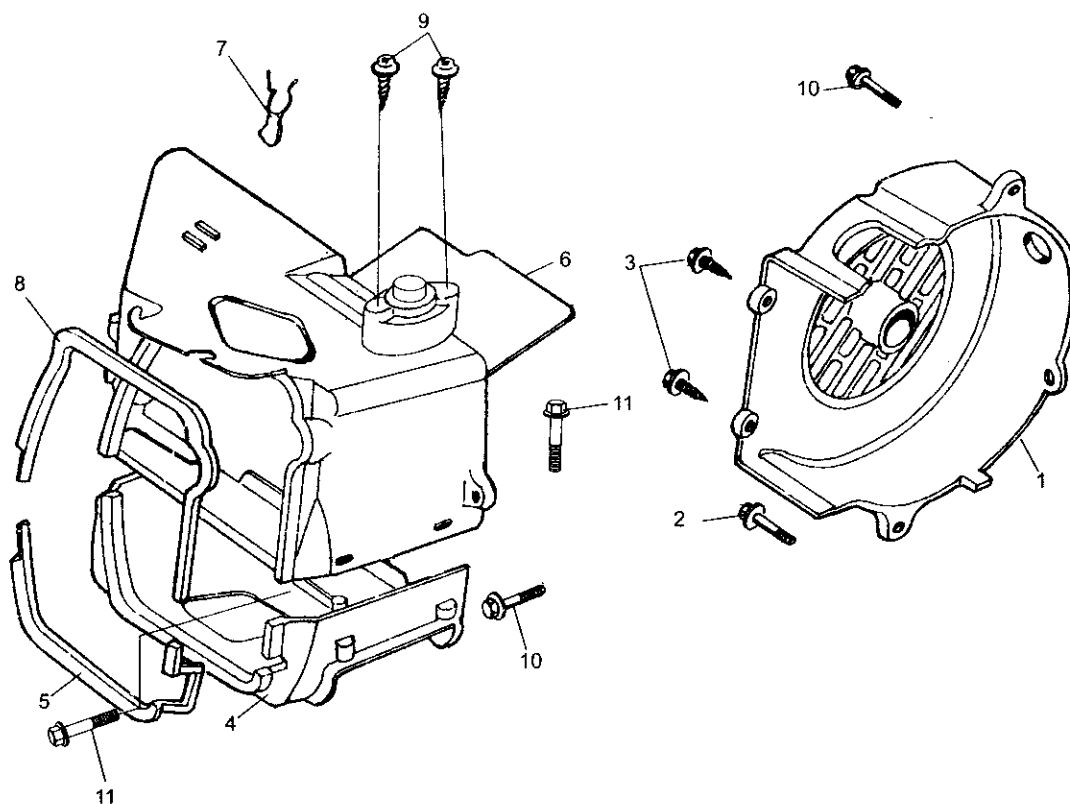

FAN COVER AND SHROUD ASSY.				
REF NO.	PART NO.	DESCRIPTION	REGD NO.	
1	M80-108001	FAN COVER COMP.	1	
2	M80-108002	BOLT M6X16	3	
3	M80-108003	SCREW ST4.8X16	2	
4	M80-108004	LOWER SHROUD	1	
5	M80-108005	LOWER SHROUD SEAL	1	
6	M80-108006	UPPER SHROUD COMP.	1	
7	M80-108007	HIGH TENSION CORD CLIP	1	
8	M80-108008	UPPER SHROUD SEAL	1	
9	M80-108009	SCREW ST4.8X16-F	2	
10	M80-108010	BOLT M6X25	3	
11	M80-108011	BOLT M6X16	2	

ELECTRIC SYSTEM

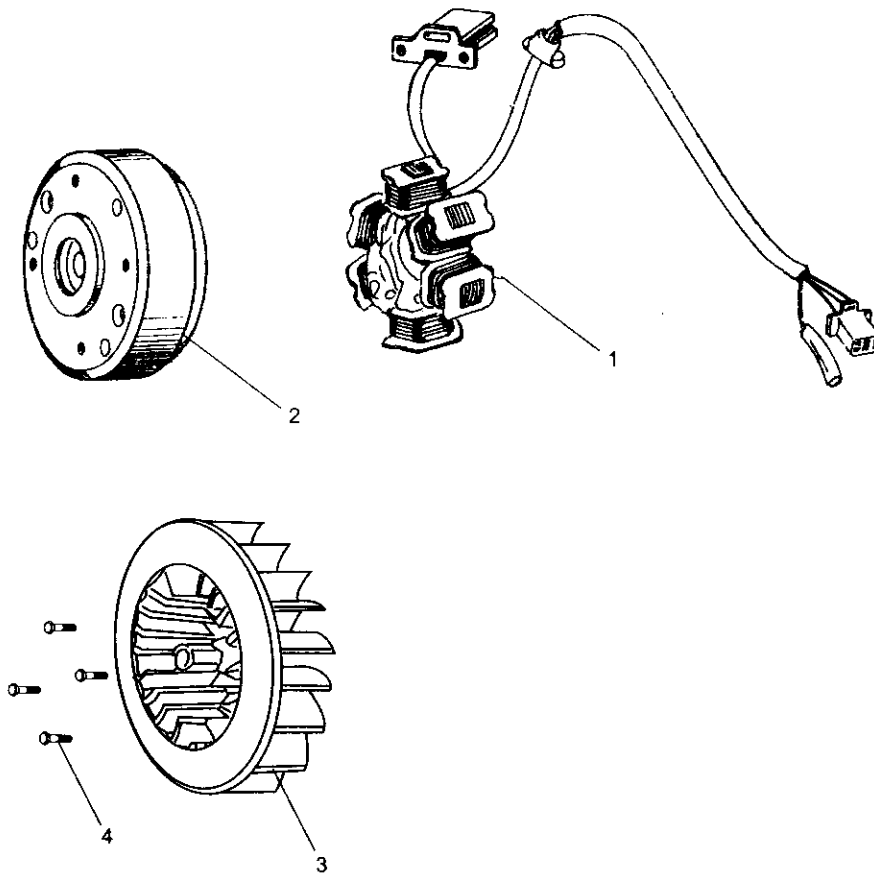

ELECTRIC SYSTEM				
REF NO.	PART NO.	DESCRIPTION	REGD NO.	
1	M80-109001	STATOR COMP.	1	
2	M80-109002	FLYWHEEL COMP.	1	
3	M80-109003	COOLING FAN COMP.	1	
4	M80-109004	FLANGE BOLT M6x18	4	

ELECTRIC STARTER ASSY.

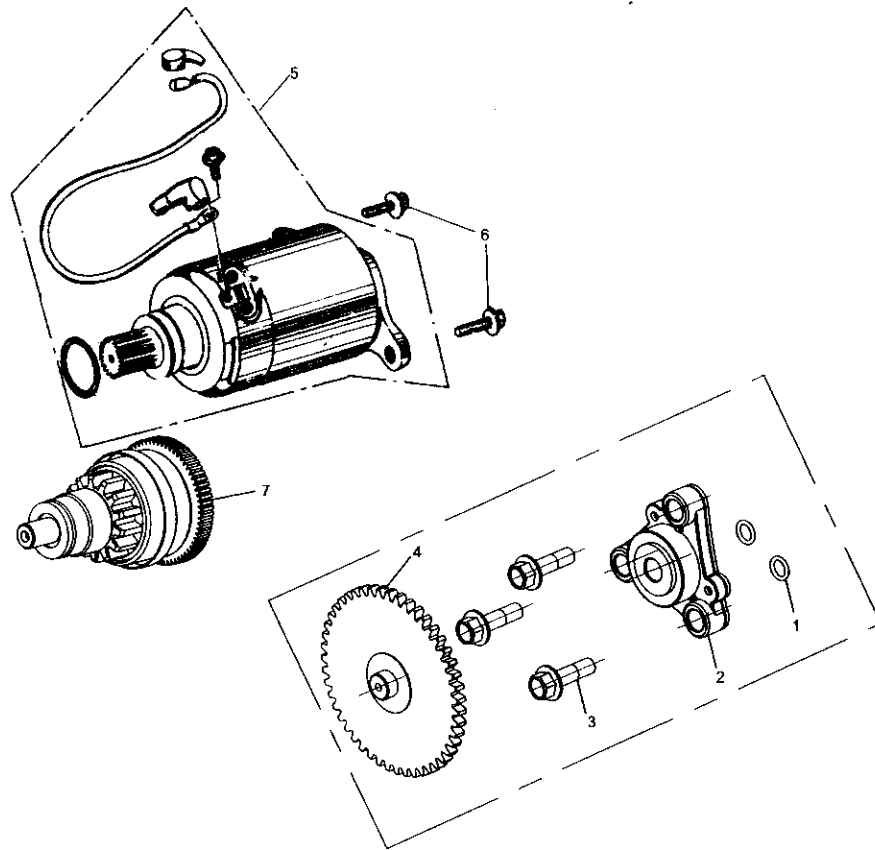
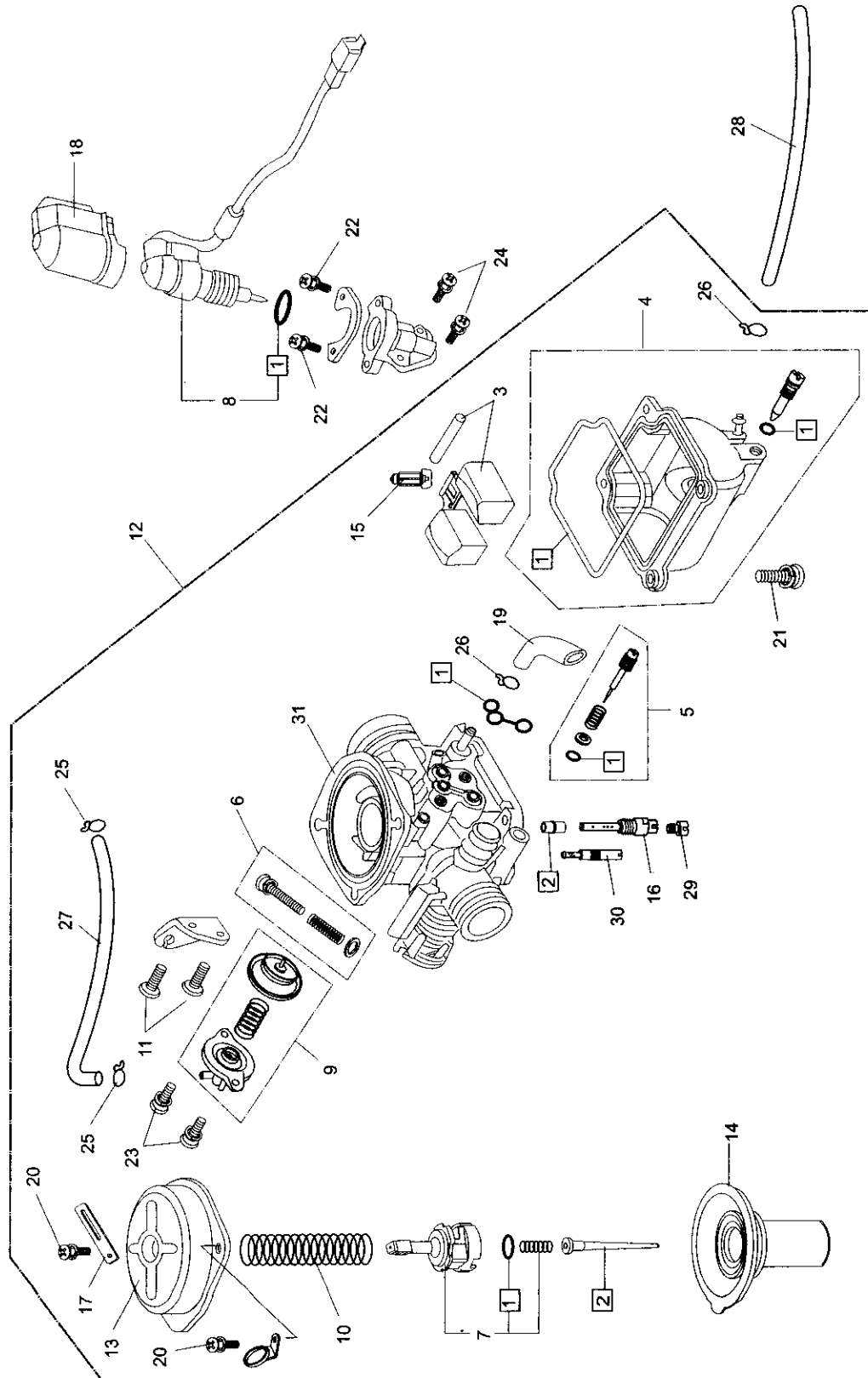
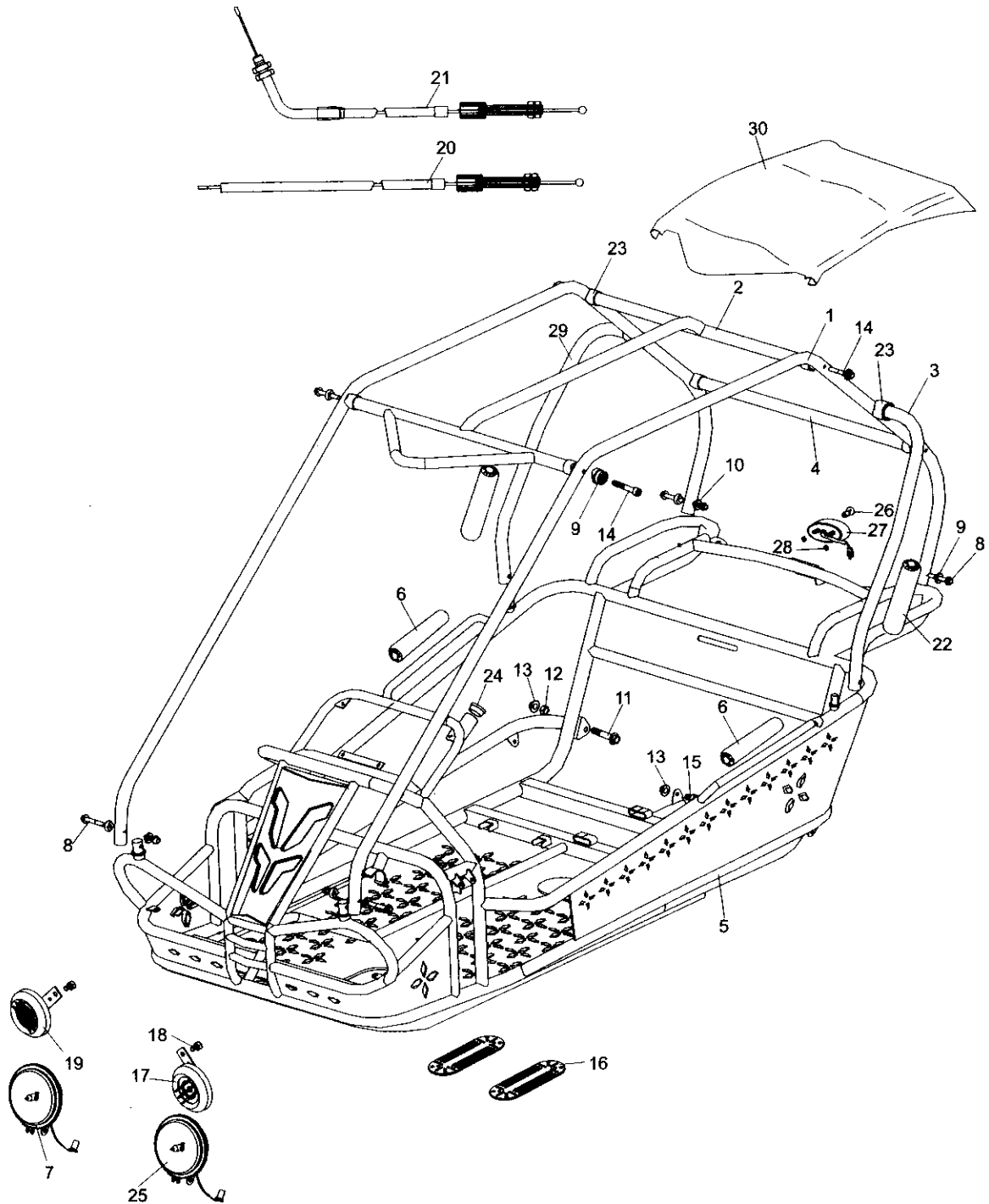

FIG. 11

CARBURETOR



FRAME GROUP



FRAME GROUP				
REF NO.	PART NO.	DESCRIPTION	REGD NO.	
1	8.070.054	C.B.C. BAR CAGE. (R.S.B)	2	
2	6.000.300	C.B.C. CUSTOM CROSS BAR TOP, FR. (R.S.B)	1	
3	8.070.055	C.B.C. CUSTOM J-BAR, L SIDE(R.S.B)	1	
4	8.080.048	C.B.C. CUSTOM CROSS BAR, RR. (R.S.B)	1	
5	2.000.054	FRAME COMP. (R.S.B)	1	
6	6.000.189	FOAM PADDING - 22	2	
7	6.000.301	HEADLIGHT, L	4	
8	9.129.840	ALLEN HEAD BOLT M8 x 1.25 x 40	6	
9	7.010.049	BAR CAGE WASHER, CAP M8	14	
10	7.010.050	BAR CAGE NUT, CAP M8	6	
11	9.110.050	FLANGE BOLT M10 x 1.25 x 50	2	
12	9.200.010	NUT, M10	2	
13	9.220.010	LOCKING FLANGE NUT, M10	3	
14	9.129.850	ALLEN HEAD NUT M8 x 1.25 x 50	8	
15	9.110.016	FLANGE BOLT M10 x 1.25 x 16	1	
16	7.020.045	RUBBER FOOT PLATE	2	
17	6.000.174	HORN, H	1	
18	9.108.010	FLANGE BOLT M10 x 1.25 x 10	2	
19	6.000.175	HORN, L	1	
20	6.000.317	THROTTLE CABLE COMP.	1	
21	6.000.318	BRAKE CABLE COMP.	1	
22	6.000.319	FOAM PADDING - 30	2	
23	7.010.045	BAR CAGE CAP	8	
24	7.010.006	STEERING SHAFT BUSH	1	
25	6.000.302	HEADLIGHT, R	1	
26	9.090.005	TAIL LIGHT BULB 21W/5W 12V	1	
27	6.000.144	TAIL LIGHT	1	
28	9.210.006	LOCK NYLON NUT M6	2	
29	8.070.056	C.B.C. CUSTOM J-BAR, R SIDE(R.S.B.)	1	
30	6.000.320	BIKINI TOP	1	

STEERING SHAFT ASSY.

REF NO.	PART NO.	DESCRIPTION	REGD NO.
1	7.010.056	STEERING BOLT COVER	1
2	9.210.006	LOCKING NYLON NUT M6	4
3	7.020.057	STEERING WHEEL	1
4	2.000.056	STEERING SHAFT	1
5	9.100.616	BOLT M6 x 16	3
6	4.000.043	STEERING GEAR	1
7	6.000.180	STEERING BALL JOINT	2
8	8.010.135	TIE ROD	2
9	6.000.181	ROD END	2
10	9.210.008	LOCKING NYLON NUT M8	2
11	9.106.020	FLANGE BOLT, M6 x 20	4
12	9.100.512	BOLT M5 x 12	2
13	9.906.625	BOLT M6x25	2
14	8.020.130	STEERING GEAR BRACKET(R.S.B.)	2
15	9.220.012	LOCKING FLANGE NUT M12	1
16	4.000.044	BRAKE PEDAL COMP.	1
17	6.000.304	BRAKE LAMP SWITCH ASSY.	1
18	6.000.305	MASTER CYLINDER	1
19	7.010.003	PEDAL BUSH	4
20	8.040.011	BRAKE PEDAL RETURN SPRING, R	1
21	8.040.010	THROTTLE PEDAL RETURN SPRING, L	1
22	9.500.218	COTTER PIN	1
23	6.000.306	CYLINDER ROD	1
24	7.020.044	GREEN THROTTLE PEDAL PAD	1
25	7.020.059	STEERING BALL JOINT DUST COVER	2
26	7.020.076	DUST COVER	1
27	9.210.006	LOCKING NYLON NUT M6	2
28	9.708.145	BRAKE PEDAL BOLT	1
29	9.200.006	HEX NUT M6	1
30	6.000.307	THROTTLE PEDAL COMP.	1
31	6.000.308	LOCKING ROLL PIN	1
32	8.010.203	KEY	1
33	7.020.082	DUST COVER	1

SUSPENSION ARM ASSY.

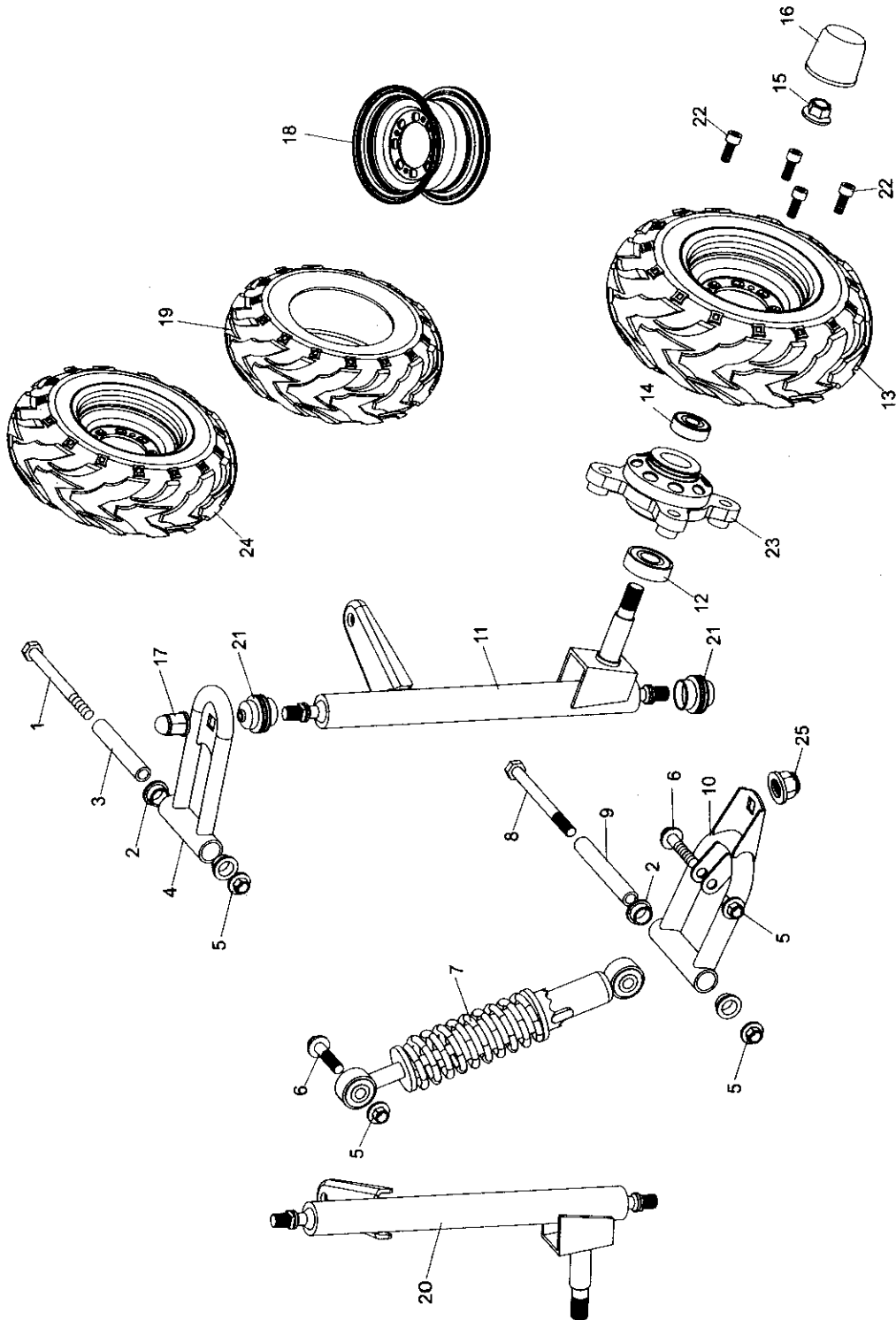

REAR SWING ARM

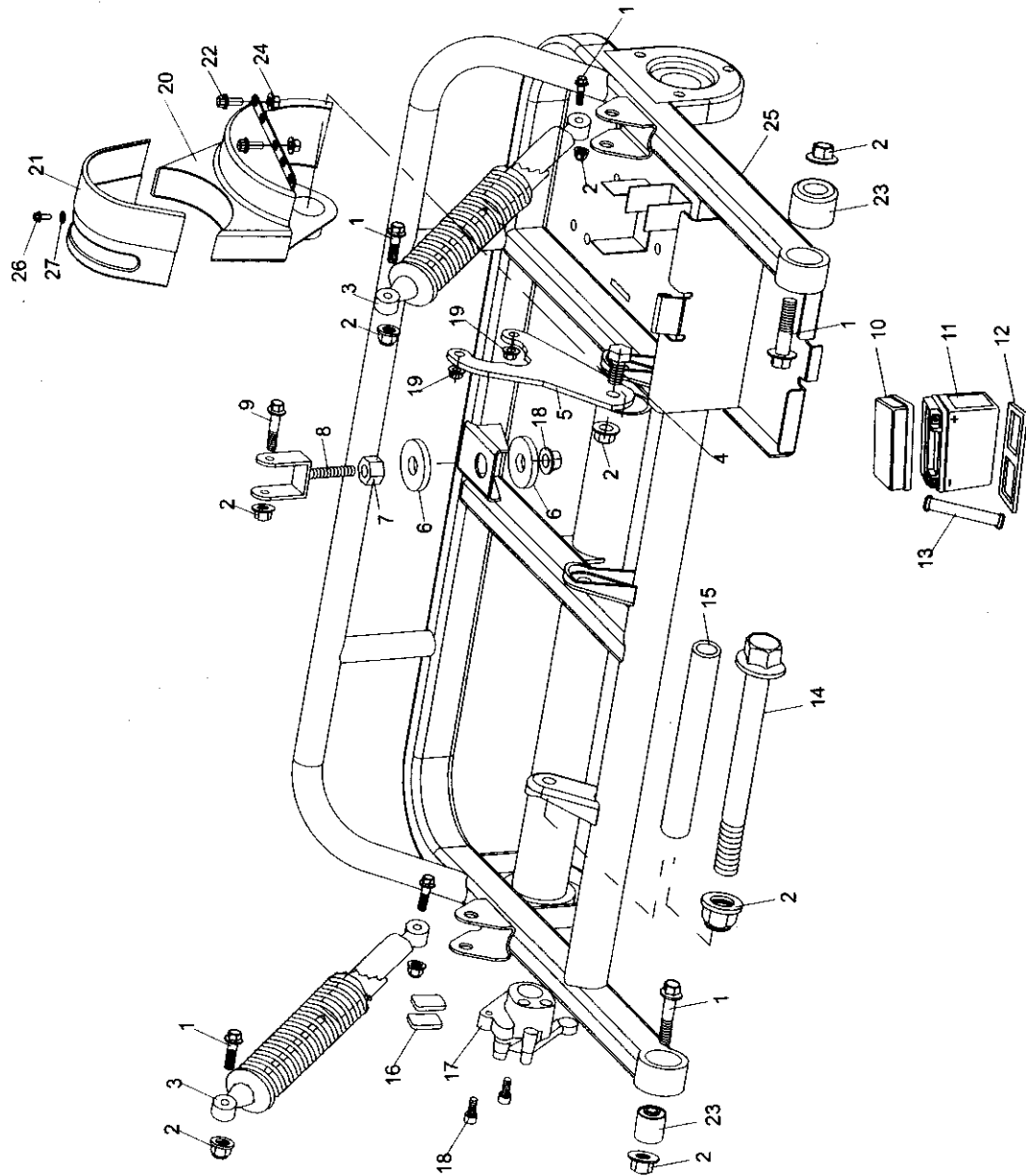

REAR HOUSING

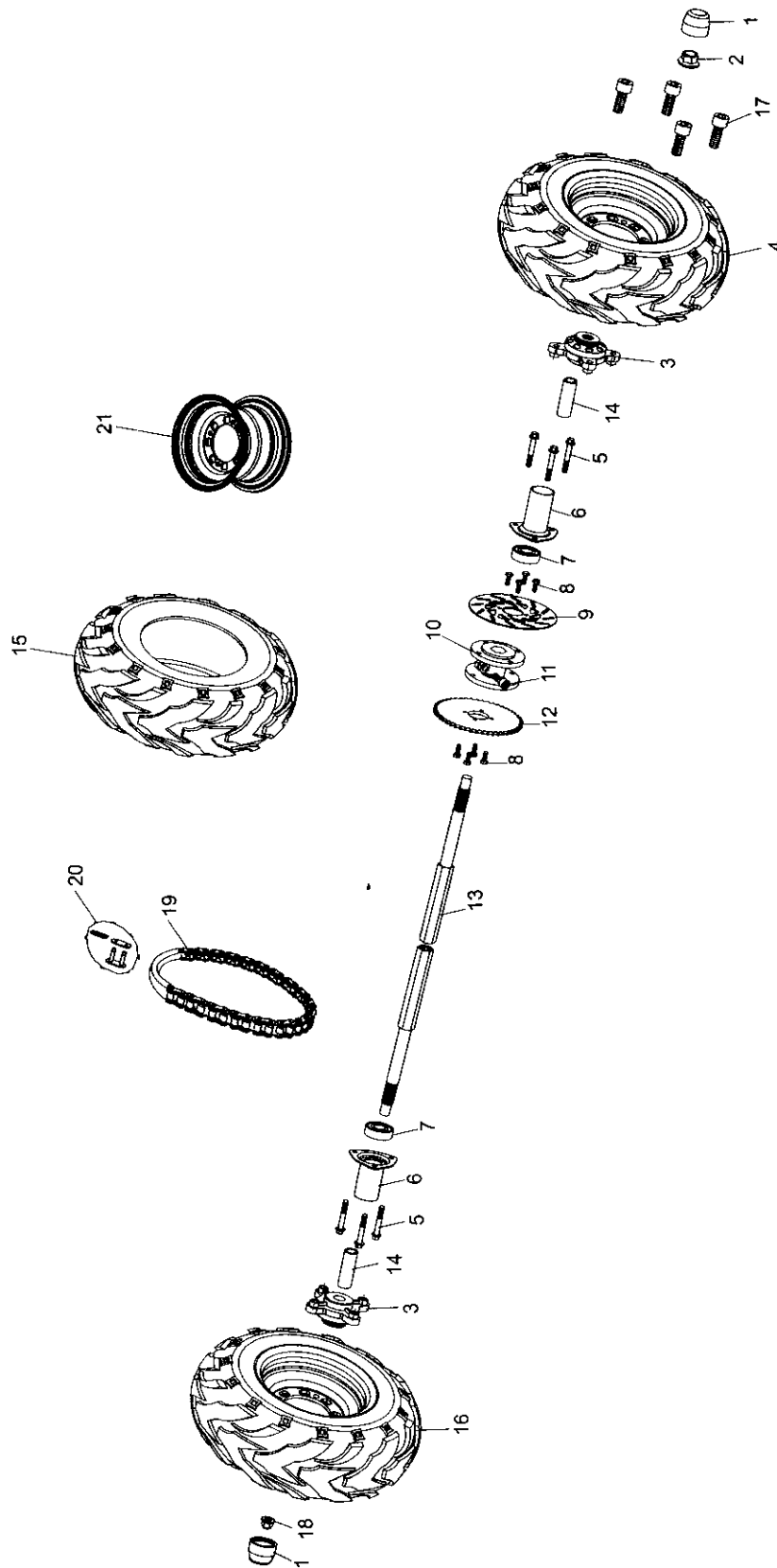

TANK AND REVERSE LEVER

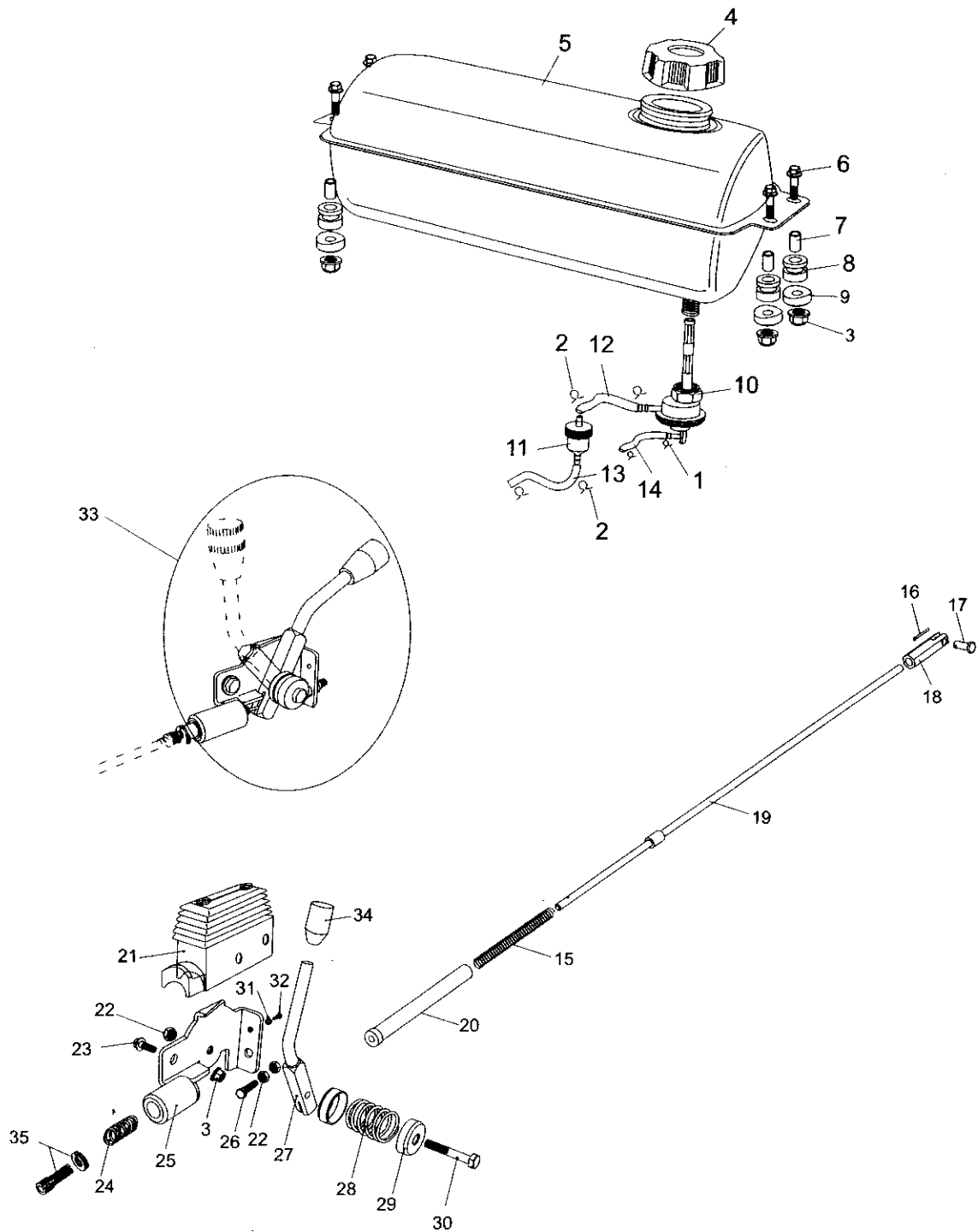

TANK AND REVERSE LEVER			
REF NO.	PART NO.	DESCRIPTION	REGD NO.
1	8.040.008	VACUUM TUBE	2
2	8.040.009	FUEL TUBE CLIP	1
3	9.220.008	LOCKING FLANGE NUT. M8	5
4	6.000.145	FUEL TANK CAP COMP.	1
5	4.000.046	FUEL TANK COMP.(B.R.S)	1
6	9.108.025	BOLT-WASHER M8X1.25X25	4
7	8.010.034	TANK COMP. COLLR	4
8	7.020.005	RUBBER MOUNT	4
9	7.010.049	BAR CAGE CAP NUT M8	4
10	6.000.046	FUEL AUTO COCK ASSY.	1
11	6.000.056	GAS FILTER	1
12	7.020.030	FUEL #1 TUBE COMP.	1
13	7.020.029	FUEL #2 TUBE COMP.	1
14	7.020.031	VACUUM TUBE COMP.	1
15	7.060.017	SLEEVE SPRING	1
16	9.500.218	COTTER PIN M2x18	1
17	6.000.308	LOCKING ROLL PIN	1
18	7.060.020	CLEVIS JOINT	1
19	7.060.018	MAIN SLEEVE	1
20	7.060.019	SLEEVE SHAFT	1
21	7.020.024	REVERSE LEVER COVER	2
22	9.210.008	LOCKING NYLON NUT M8	6
23	9.108.020	BOLT-WASHER M8x1.25x20	2
24	8.040.004	CABLE SPRING	2
25	6.000.327	LEVER BRACKET	1
26	9.100.830	BOLT M8x30	1
27	6.000.326	LEVER, REVERSE, PARKING BRAKE	1
28	8.040.003	LEVER SPRING	1
29	8.020.082	LEVER SPACER	1
30	9.108.040	BOLT-WASHER M8x1.25x40	1
31	9.300.005	WASHER FLAT Φ 5	1
32	9.600.512	PAN SCREW M5x12	1
33	6.000.325	REVERSE LEVER ASSY.	1
34	7.020.026	LEVER. GREEN / BLACK COVEV	1
35	6.000.051	CABLE ROD ADJUSTING	1

WIRE HARNESS/ELECTRICAL/SEATS/ENGINE

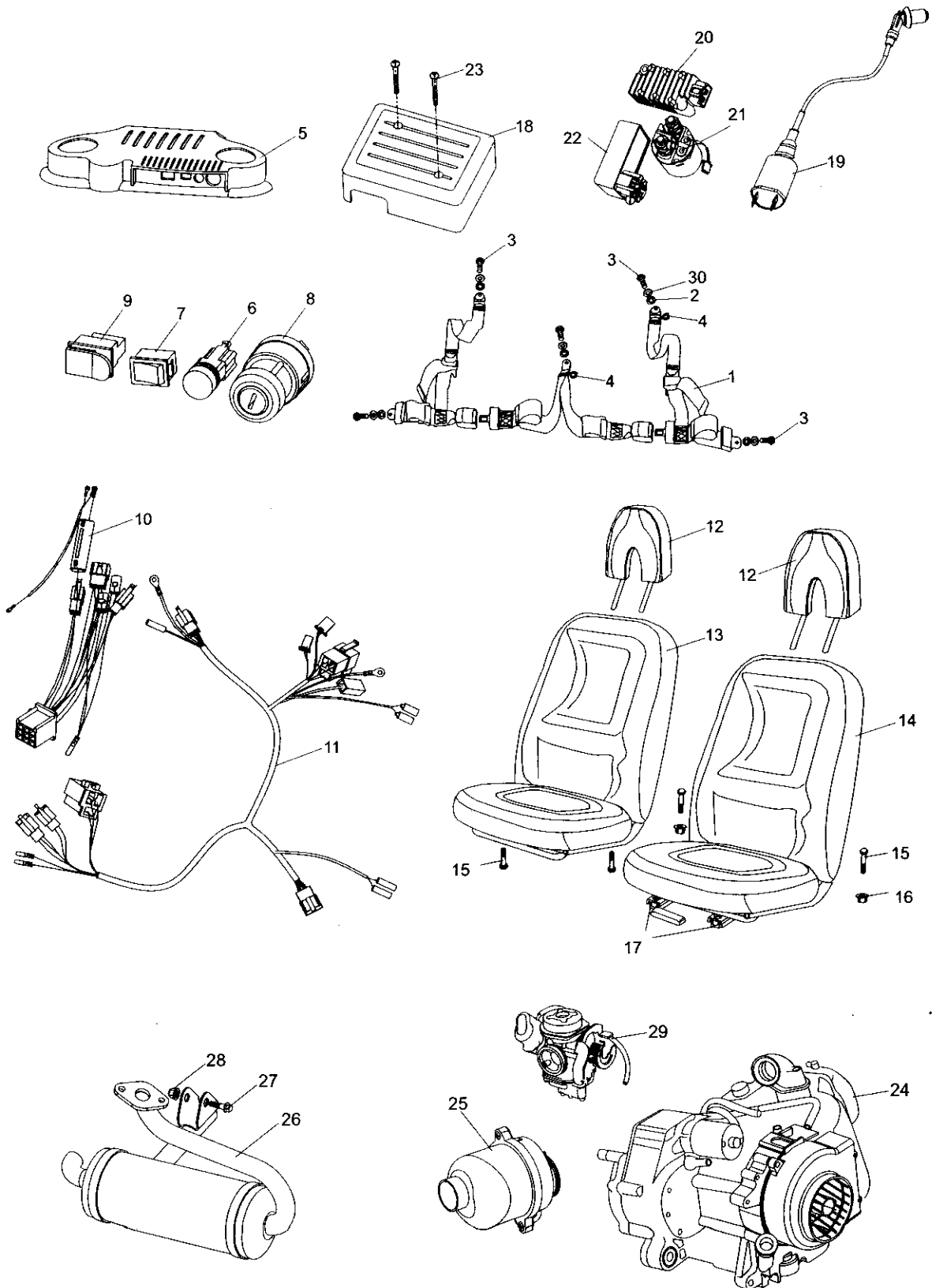

WIRE HARNESS/ELECTRICAL/SEATS/ENGINE				
REF NO.	PART NO.	DESCRIPTION	REGD NO.	
1	6.000.328	SAFETY BELT	1	
2	9.700.002	BELT WASHER Φ 12	5	
3	9.700.001	SPECIAL BOLT M7/16"X28	5	
4	9.7000.003	BELT NUT M7/16"	5	
5	7.010.076	SWITCH PANEL COVER	1	
6	6.000.164	ENGINE STOP BUTTON	1	
7	6.000.334	HEADLIGHT SWITCH	1	
8	6.000.165	POWER ON SWITCH	1	
9	6.000.299	HORN BUTTON	1	
10	6.000.312	SOCKET COMP.	1	
11	6.000.313	WIRE HARNESS	1	
12	6.000.329	HEAD-REST	2	
13	6.000.330	SEAT COMP. R	1	
14	6.000.331	SEAT COMP. L	1	
15	9.900.840	BOLT STRAP M8X1.25X40	2	
16	9.220.008	LOCKING FLANGE NUT M8	2	
17	6.000.057	SEAT RALL SET	1	
18	7.010.077	ELECTRIC ASSY. COVER	1	
19	6.000.332	IGNITION COIL COMP	1	
20	6.000.167	RECTIFIER COMP. REGULATE	1	
21	6.000.296	STARTING RELAY	1	
22	6.000.314	C.D.I UNIT COMP.	1	
23	9.600.655	PAN SCREW M6X55	2	
24	7.060.012	ENGINE COMP.	1	
25	7.060.015	AIR CLEANER ASSY.	1	
26	7.060.014	MUFFLER COMP.	1	
27	9.110.040	FLANGE BOLT M10X40	1	
28	9.220.010	LOCKING FLANGE NUT M10	1	
29	7.060.013	CARBURETOR	1	
30	7.060.022	LOCKING WASHER	5	

FIG.19

WARNING STICKERS

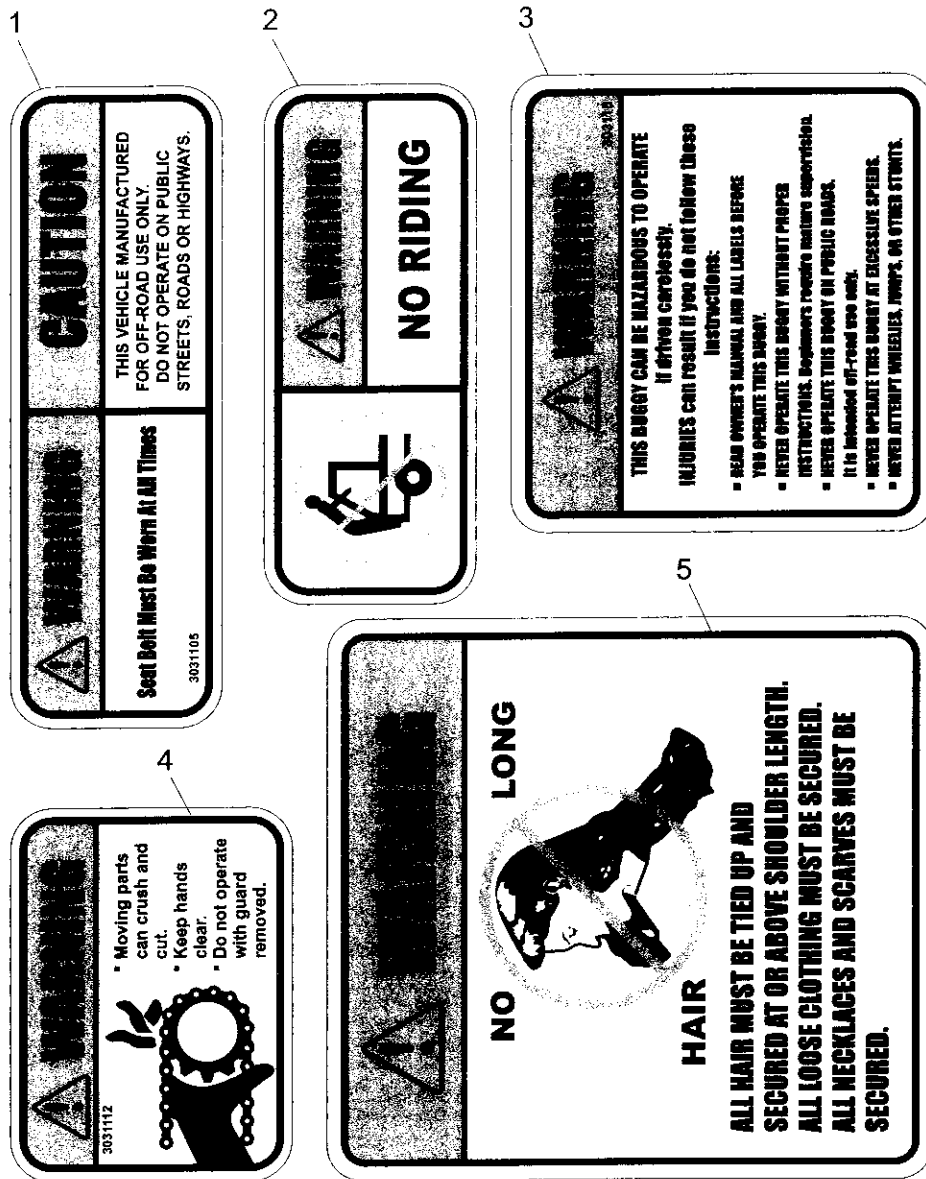

WARNING STICKERS			
REF NO.	PART NO.	DESCRIPTION	REGD NO.
1	9.090.014	LABEL SEAT BELT	1
2	9.090.008	LABEL NO CLIMBING	1
3	9.090.022	LABEL WARNING	1
4	9.090.009	LABEL CHAIN GUARD	1
5	9.090.021	LABEL WARNING	1